



WORKWEAR

CATALOGUE



VOLUME 10

“IT’S GOTTA BE RITEMATE”

RITEMATE WORKWEAR

is an innovative workwear brand that is rapidly expanding on the Australian market.

Having a major involvement in the Australian textile and clothing industry over the last thirty years, the executives of Ritemate bring a wealth of experience and knowledge to a growing range of high quality products that are fast gaining popular consumer recognition amid a myriad of high profile workwear names.

When asked "what is the point of difference between Ritemate Workwear and other more well known and longer established brands", we are proud to say that though Ritemate is 'the new kid on the block', our vast experience and wealth of knowledge within the textile and clothing industry allows us to offer consumers, through selected stockist a range of high quality work wear products with value for money in the Ritemate brand. Ritemate is backed up by the three important elements essential to the needs of consumers: "Service, Quality and Price". Our highly reputable parent company was established in 1977 and we would never have been around for that long without recognising the needs of our customers and following through with a service attitude that we believe is second to none"

Styling, fit and fabric performance are key features in the Ritemate range of industrial workwear and high visibility safety garments. Ritemate General Manager, David Mair says "Practical designs, wearing comfort and hard wearing fabrics all combine to give our exciting new brand the acceleration that we are currently experiencing in this broad spectrum work wear market".

The distinctive and iconic Ritemate logo with the hand giving the proverbial 'thumbs up' sign is all about the Aussie larrikin attitude so I guess the accompanying caption says it all:

"IT'S GOTTA BE RITEMATE"





CONTENT

SHIRTS

RM1050R	2 tone open front long sleeve shirt with 3M 8910 reflective tape.....	6
RM1050RS	2 tone open front short sleeve shirt with 3M 8910 reflective tape.....	8
RM1050	2 tone open front long sleeve shirt.....	9
RM1050S	2 tone open front short sleeve shirt.....	11
RM106XR	Open front long sleeve shirt with "X" back 3M 8910 reflective tape	12
RM109VXR	Vented light weight open front long sleeve shirt with "X" back 3M 8910 reflective tape	13
RM105CFR	2 tone closed front long sleeve shirt with 3M 8910 reflective tape	14
RM105CF	2 tone closed front long sleeve shirt	15
RM105CFS	2 tone closed front short sleeve shirt	16
RM104CFR	Closed front long sleeve shirt with 3M 8910 reflective tape	17
RM1040R	Open front long sleeve shirt with 3M 8910 reflective tape	18
RM1000	Open front long sleeve shirt	21
RM1000S	Open front short sleeve shirt	22
RM100CF	Closed front long sleeve shirt	23
RM100CFS	Closed front short sleeve shirt	24
RM208V2R	Ladies 2 tone vented light weight open front long sleeve shirt with 3M 8910 reflective tape	25
RM208V3R	Ladies vented light weight open front long sleeve shirt with 3M 8910 reflective tape	26
RM107V2	2 tone vented light weight open front long sleeve shirt	28
RM107V2S	2 tone vented light weight open front short sleeve shirt	29
RM107V2R	2 tone vented light weight open front long sleeve shirt with 3M 8910 reflective tape.....	30
RM107V2RS	2 tone vented light weight open front short sleeve shirt with 3M 8910 reflective tape.....	31
RM108V3	Vented light weight open front long sleeve shirt	32
RM108V3R	Vented light weight open front long sleeve shirt with 3M 8910 reflective tape	33
RM400CF	Children's Pilbara closed front long sleeve shirt	34
RM4050R	Children's 2 tone open front long sleeve shirt with reflective tape	35
RM200CF	Pilbara men's closed front long sleeve shirt	36
RM300CF	Pilbara ladies closed front long sleeve shirt	39
RM500BT	Pilbara men's open front long sleeve shirt	40
RM200CFS	Pilbara men's closed front short sleeve shirt	42
RM500BTS	Pilbara men's open front short sleeve shirt	43
RM123FCF & RM123QS	Flannelette garments	44
RM123V & RM123FOF	Flannelette garments	45
RM2346	Hi viz long sleeve polo shirt	74
RM2346S	Hi viz short sleeve polo shirt	75

PANTS

RM1002	Belt loop drill trouser	46
RM1002R	Belt loop drill trouser with 3M 8910 reflective tape	48
RM1004R	Cargo trouser with 3M 8910 reflective tape.....	49
RM1004	Cargo trouser.....	51
RM8080	Light weight 8080 cargo trouser – unisex trouser	55
RM1007	Mid weight cargo trouser	59
RM411CP	CORDURA® cargo trouser	63
RM106DJ	Denim jeans.....	66
RM106DJR	Denim jeans with 3M 8910 reflective tape.....	67
RM110SD	Stretch denim jeans.....	68
RM110SDR	Stretch denim jeans with 3M 8910 reflective tape.....	69
RM220LSD	Ladies stretch denim jeans	72
RM220LSDR	Ladies stretch denim jeans with 3M 8910 reflective tape	73

SHORTS

RM1002S	Belt loop and side tab combo short	52
RM1004S	Cargo short	53
RM4040	Light weight 4040 cargo short – unisex short.....	54
RM33EWLS	Elastic waist long leg short.....	56
RM301EWS	Elastic waist rugby short.....	58
RM411CS	CORDURA® cargo short.....	64
RM112TSD	Denim Trucker Short (Jean Short).....	71

COVERALLS

RM1008M	Coverall.....	60
RM908CR	2 tone coverall with 3M 8910 reflective tape	61
RM909AR	2 tone action back overall with 3M 8910 reflective tape	62

OUTER WEAR

RM4245	Hi viz vest	76
RM4245T	Day/night vest with 3M reflective tape	77
RM6012	Half zip fleecy pullover	78
RM6012R	Half zip fleecy pullover with 3M reflective tape	79
RM5071R	2 tone 100% cotton drill jacket with 3M 8910 reflective tape	80
RM73N1R	4 in 1 two tone 100% cotton drill jacket with 3M 8910 reflective tape	81

RM1050R

2 tone open front long sleeve shirt with 3M 8910 reflective tape

FEATURES

- Superior garment assembly, twin needle stitching and bar tacks for extra strength
- UPF 50+ meets Australian standard AS/NZS 4399:1996
- Meets Australian standard AS/NZS 1906.4:2010 & AS/NZS Q4602.1:2011 for high visibility day/night wear

SIZE

XS - 5XL (2XS available in Pink/Navy, Blue/Navy, Emerald/Navy)

WEIGHT

Regular weight - 190gsm

QUALITY

Premium quality mercerized, double pre-shrunk, 100% cotton twill

COLOURS

Yellow/Navy, Orange/Navy, Yellow/Bottle, Pink/Navy (for night use only), Blue/Navy (for night use only), Emerald/Navy (for night use only)

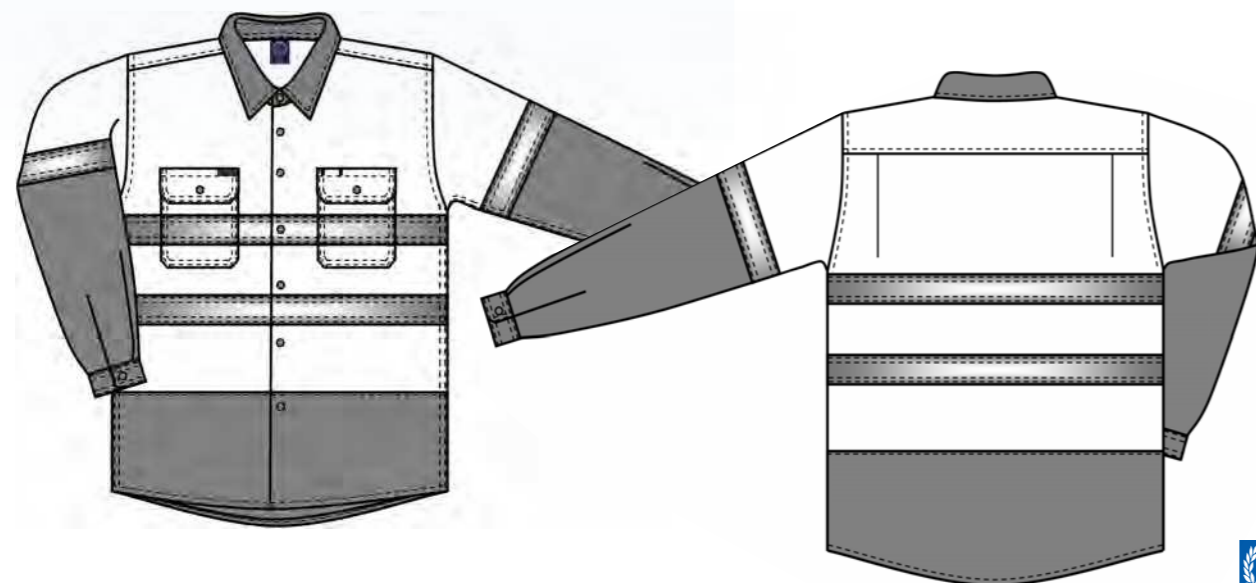

“IT’S GOTTA BE RITEMATE”



RM1050RS

2 tone open front short sleeve shirt with 3M 8910 reflective tape

FEATURES

- Superior garment assembly, twin needle stitching and bar tacks for extra strength
- UPF 50+ meets Australian standard AS/NZS 4399:1996
- Meets Australian standard AS/NZS 1906.4:2010 & AS/NZS Q4602.1:2011 for high visibility day/night wear

SIZE

XS - 5XL (2XS available in Pink/Navy, Blue/Navy, Emerald/Navy)

WEIGHT

Regular weight - 190gsm

QUALITY

Premium quality mercerized, double pre-shrunk, 100% cotton twill

COLOURS

Yellow/Navy, Orange/Navy, Yellow/Bottle, Pink/Navy (for night use only), Blue/Navy (for night use only), Emerald/Navy (for night use only)

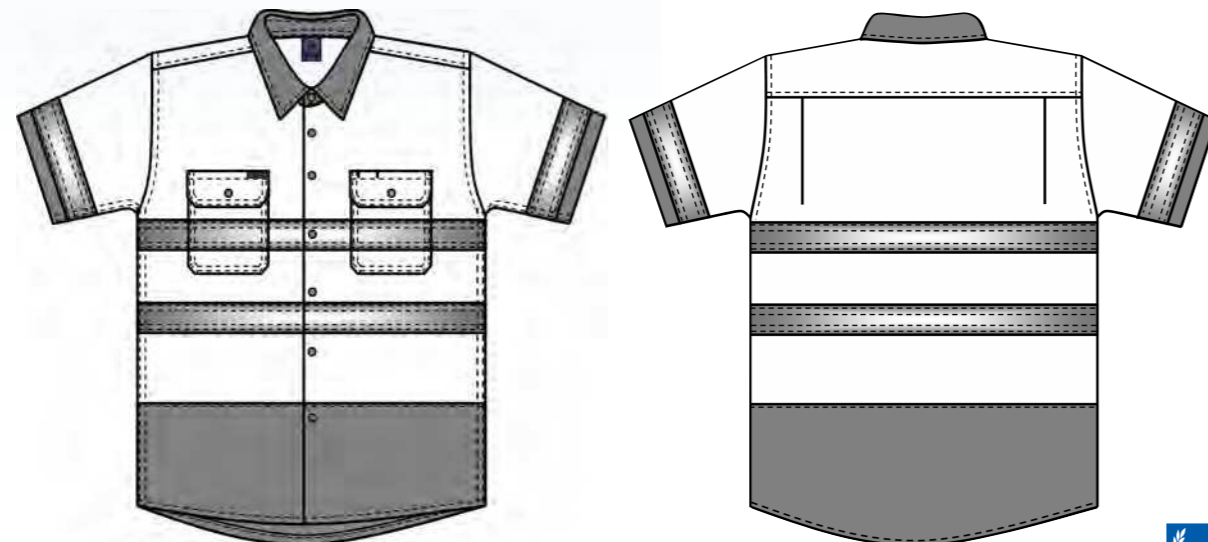

RM1050

2 tone open front long sleeve shirt

FEATURES

- Superior garment assembly, twin needle stitching and bar tacks for extra strength
- UPF 50+ meets Australian standard AS/NZS 4399:1996
- Meets Australian standard AS/NZS 4602.1:2011 for high visibility day wear

SIZE

XS - 5XL

WEIGHT

Regular weight - 190gsm

QUALITY

Premium quality mercerized, double pre-shrunk, 100% cotton twill

COLOURS

Yellow/Navy, Orange/Navy, Yellow/Bottle,

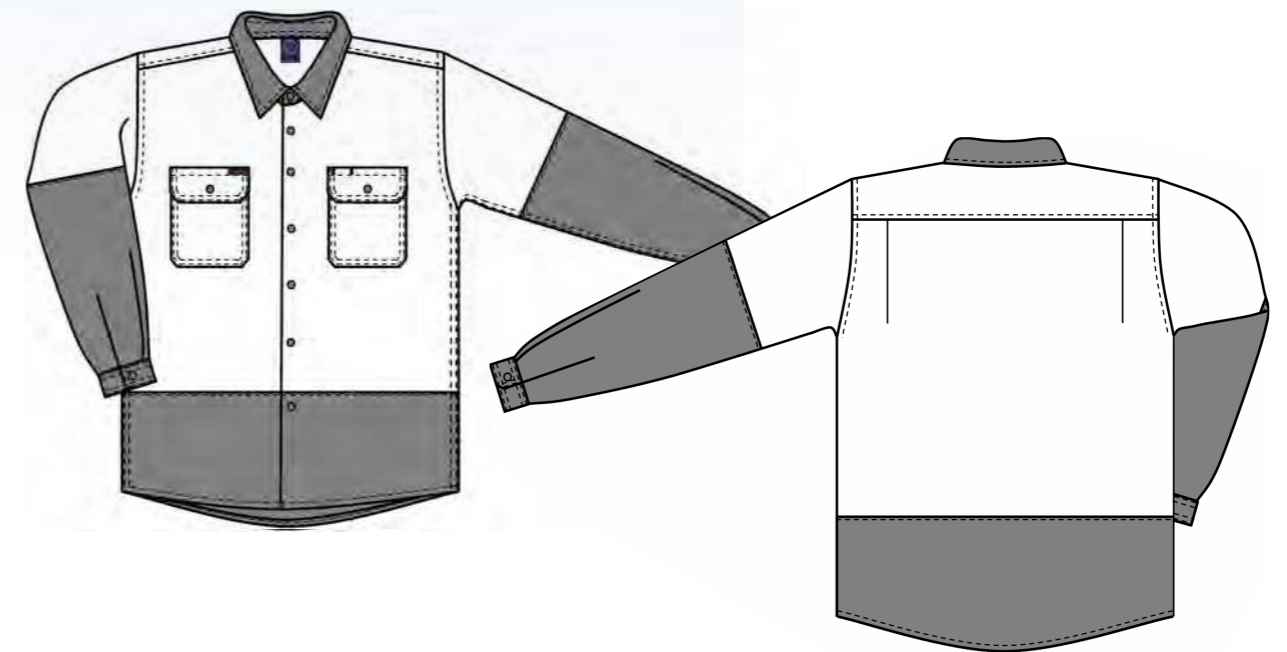

“IT’S GOTTA BE RITEMATE”

RM1050S



2 tone open front short sleeve shirt

FEATURES

- Superior garment assembly, twin needle stitching and bar tacks for extra strength
- UPF 50+ meets Australian standard AS/NZS 4399:1996
- Meets Australian standard AS/NZS 4602.1:2011 for high visibility day wear

SIZE

XS - 5XL

WEIGHT

Regular weight - 190gsm

QUALITY

Premium quality mercerized, double pre-shrunk, 100% cotton twill

COLOURS

Yellow/Navy, Orange/Navy

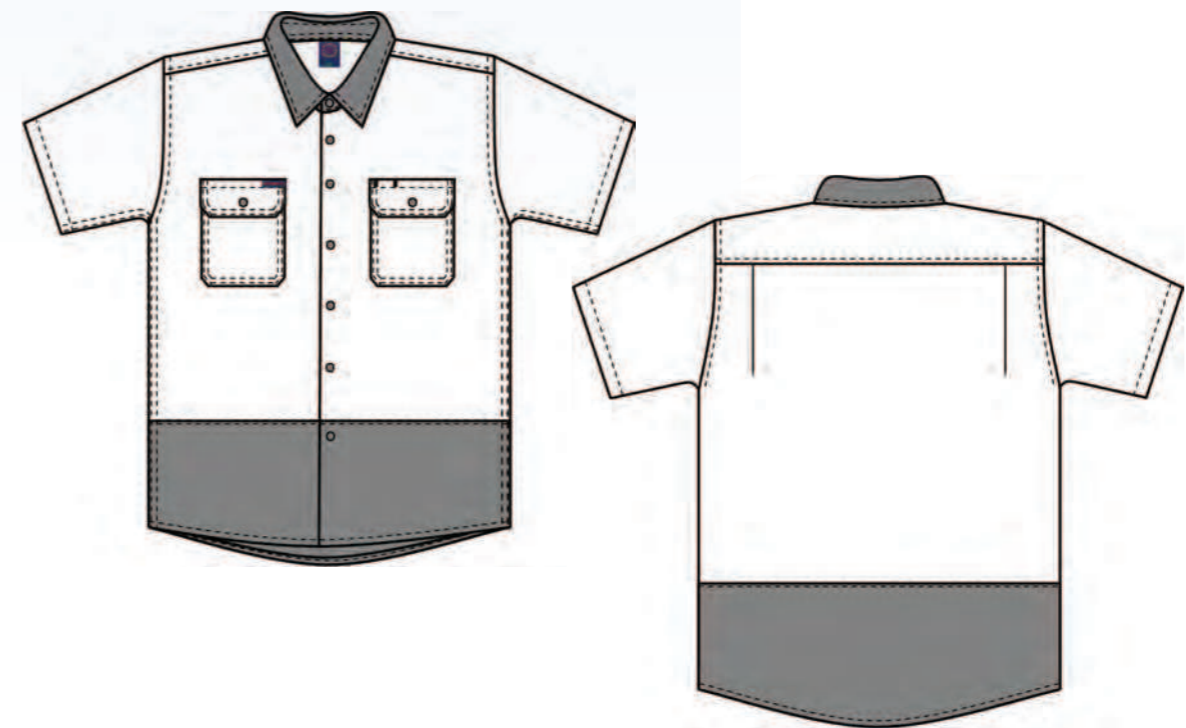

RM106XR

Open front long sleeve shirt with "X" back 3M 8910 reflective tape

FEATURES

- Superior garment assembly, twin needle stitching and bar tacks for extra strength
- UPF 50+ meets Australian standard AS/NZS 4399:1996
- Meets Australian standard AS/NZS 1906.4:2010 & AS/NZS 4602.1:2011 for high visibility day/night wear
- Available in short sleeve upon request

SIZE

XS - 5XL

WEIGHT

Regular weight - 190gsm

QUALITY

Premium quality mercerized, double pre-shrunk, 100% cotton twill

COLOURS

Orange

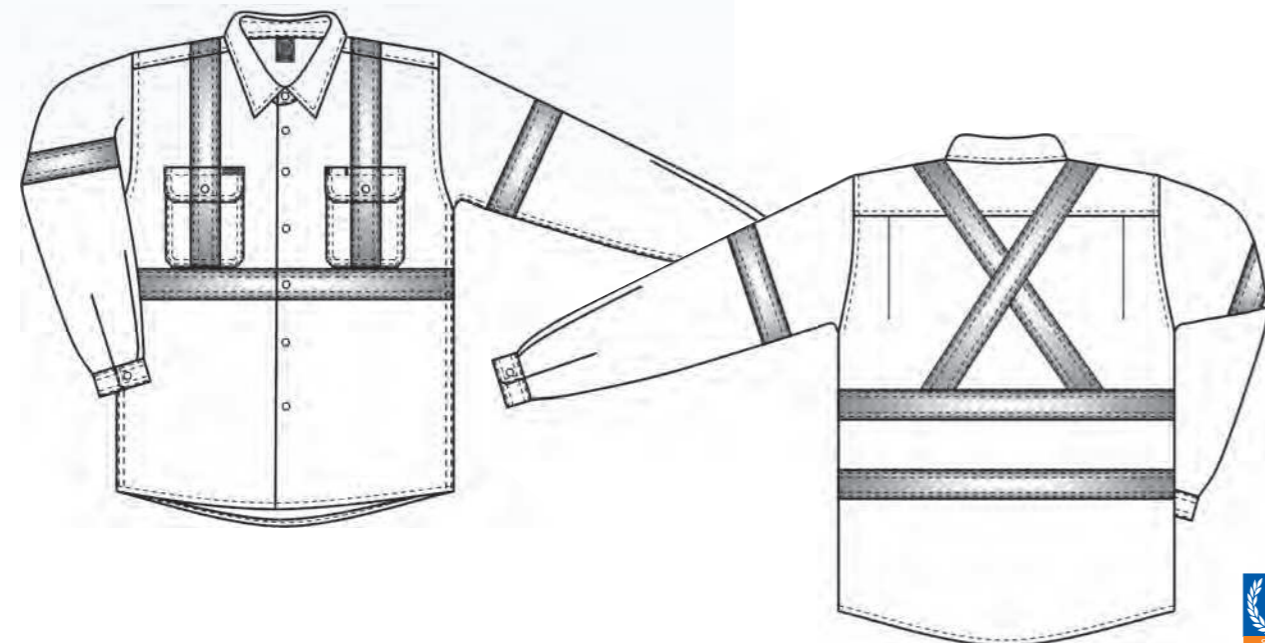

RM109VXR

Vented light weight open front long sleeve shirt with "X" back 3M 8910 reflective tape

FEATURES

- Cotton mesh cooling vents located at underarm and shoulder positions
- Superior garment assembly, twin needle stitching and bar tacks for extra strength
- UPF 50+ meets Australian standard AS/NZS 4399:1996
- Meets Australian standard AS/NZS 1906.4:2010 & AS/NZS 4602.1:2011 for high visibility day/night wear
- Available in short sleeve upon request

SIZE

XS - 5XL

WEIGHT

Light weight - 150gsm

QUALITY

Premium quality mercerized, double pre-shrunk, 100% cotton twill

COLOURS

Orange

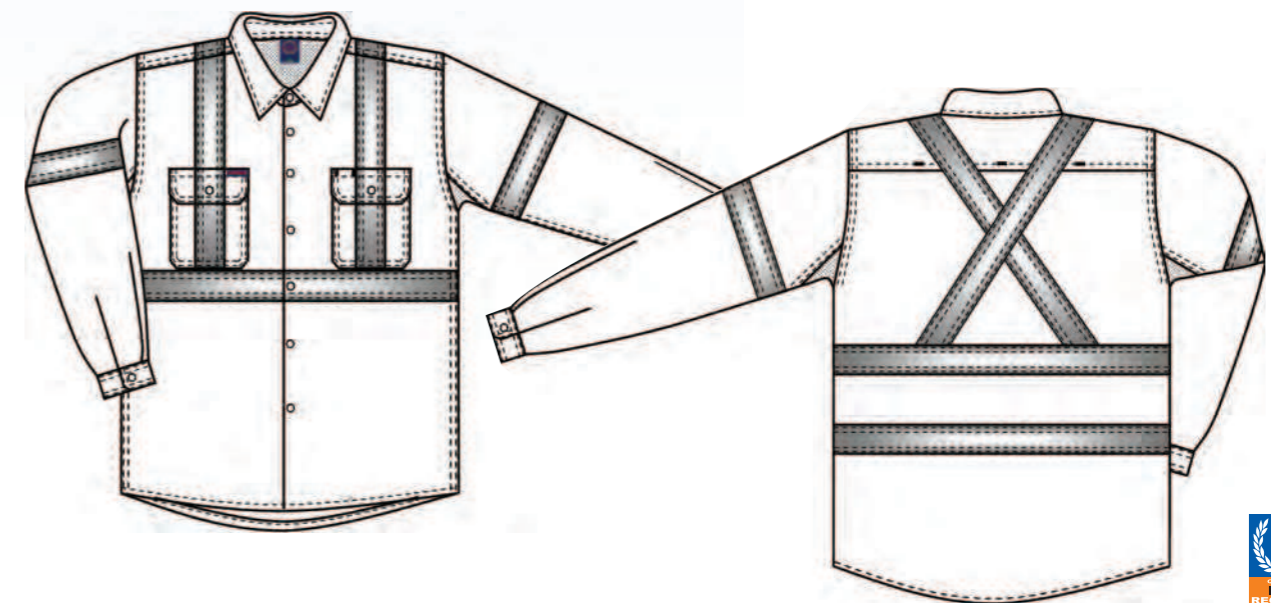
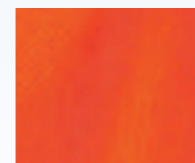

RM105CFR

2 tone closed front long sleeve shirt with 3M 8910 reflective tape

FEATURES

- Superior garment assembly, twin needle stitching and bar tacks for extra strength
- UPF 50+ meets Australian standard AS/NZS 4399:1996
- Meets Australian standard AS/NZS 1906.4:2010 & AS/NZS 4602.1:2011 for high visibility day/night wear
- Available in short sleeve upon request

SIZE

XS - 5XL

WEIGHT

Regular weight - 190gsm

QUALITY

Premium quality mercerized, double pre-shrunk, 100% cotton twill

COLOURS

Yellow/Navy, Orange/Navy

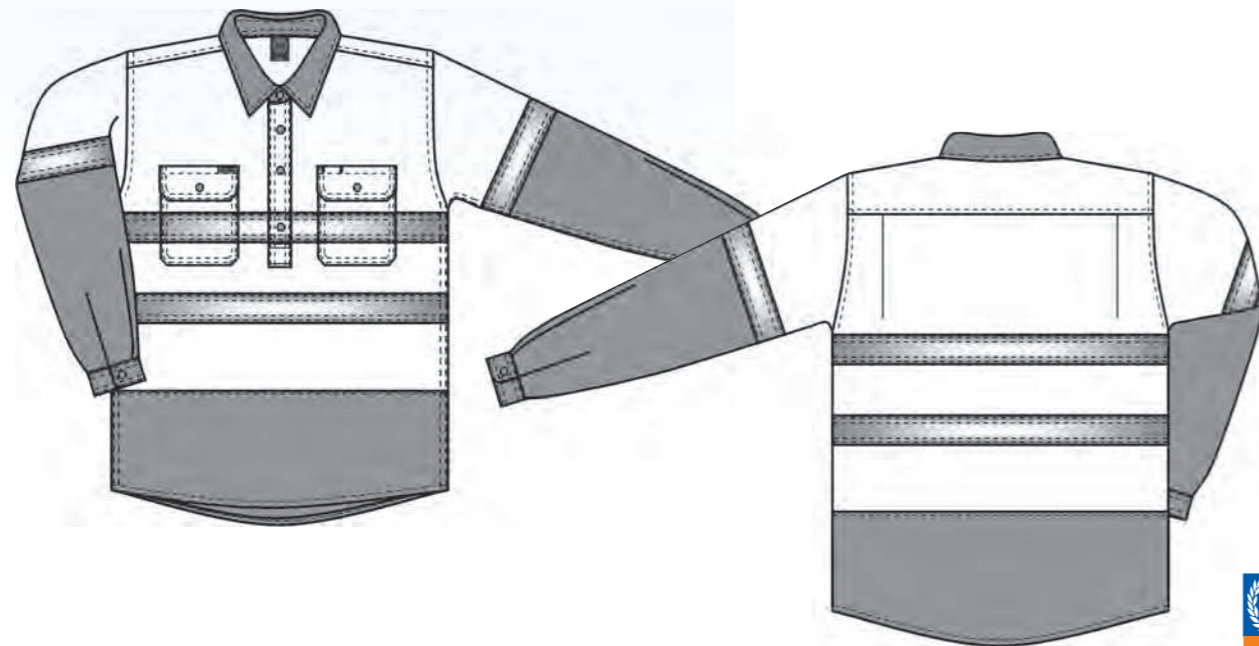

RM105CF

2 tone closed front long sleeve shirt

FEATURES

- Superior garment assembly, twin needle stitching and bar tacks for extra strength
- UPF 50+ meets Australian standard AS/NZS 4399:1996
- Meets Australian standard AS/NZS 4602.1:2011 for high visibility day wear

SIZE

XS - 5XL

WEIGHT

Regular weight - 190gsm

QUALITY

Premium quality mercerized, double pre-shrunk, 100% cotton twill

COLOURS

Yellow/Navy, Orange/Navy, Yellow/Bottle

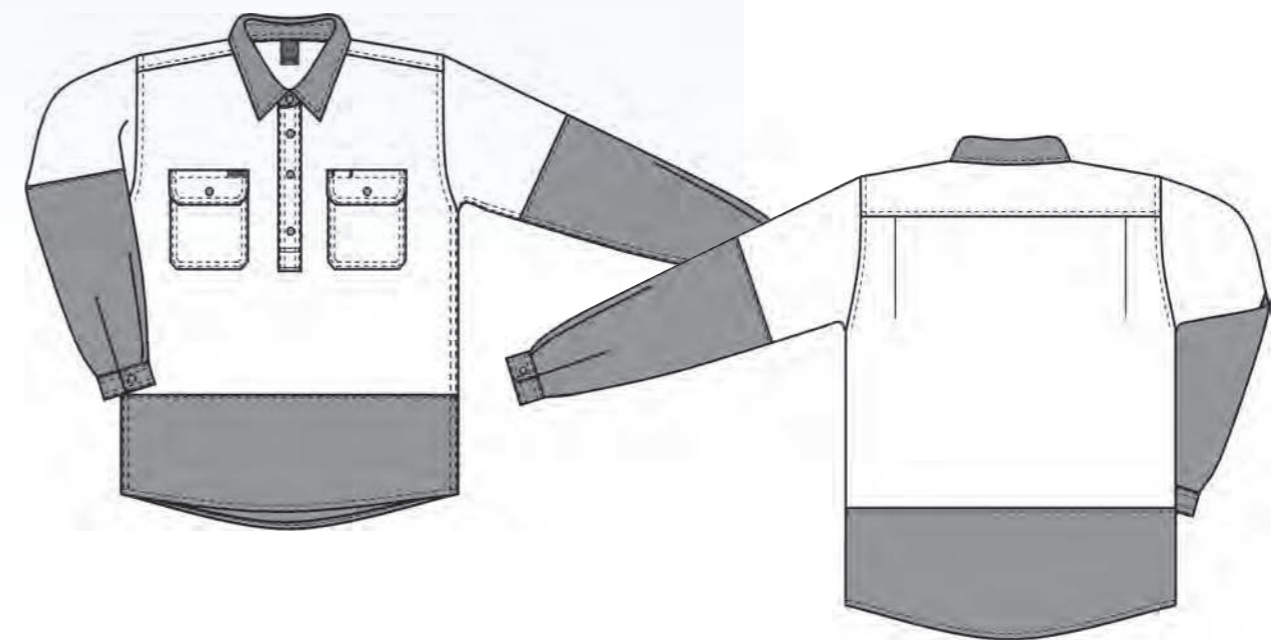

RM105CFS

2 tone closed front short sleeve shirt

FEATURES

- Superior garment assembly, twin needle stitching and bar tacks for extra strength
- UPF 50+ meets Australian standard AS/NZS 4399:1996
- Meets Australian standard AS/NZS 4602.1:2011 for high visibility day wear

SIZE

XS - 5XL

WEIGHT

Regular weight - 190gsm

QUALITY

Premium quality mercerized, double pre-shrunk, 100% cotton twill

COLOURS

Yellow/Navy, Orange/Navy, Yellow/Bottle



RM104CFR

Closed front long sleeve shirt with 3M 8910 reflective tape

FEATURES

- Superior garment assembly, twin needle stitching and bar tacks for extra strength
- UPF 50+ meets Australian standard AS/NZS 4399:1996
- Meets Australian standard AS/NZS 1906.4:2010 & AS/NZS 4602.1:2011 for high visibility day/night wear
- Available in short sleeve upon request

SIZE

XS - 5XL

WEIGHT

Regular weight - 190gsm

QUALITY

Premium quality mercerized, double pre-shrunk, 100% cotton twill

COLOURS

Orange

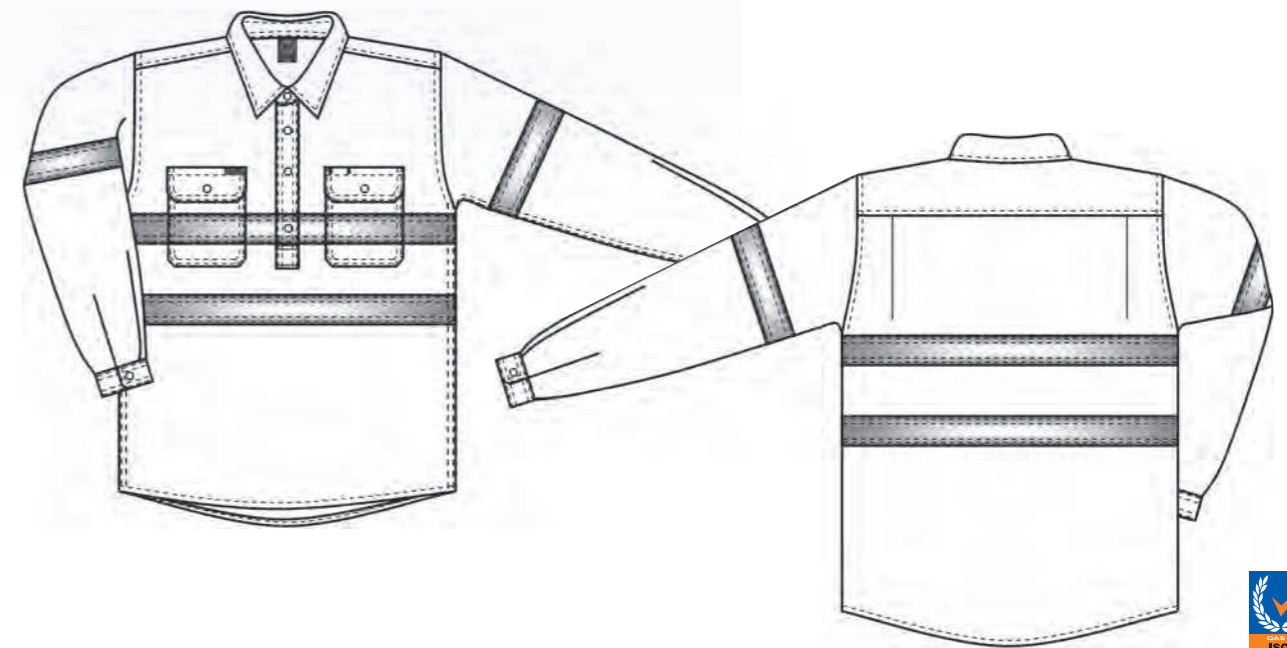
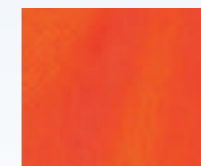

RM1040R

Open front long sleeve shirt with 3M 8910 reflective tape

FEATURES

- Superior garment assembly, twin needle stitching and bar tacks for extra strength
- UPF 50+ meets Australian standard AS/NZS 4399:1996
- Meets Australian standard AS/NZS 1906.4:2010 & AS/NZS 4602.1:2011 for high visibility day/night wear
- Available in short sleeve upon request

SIZE

XS - 5XL

WEIGHT

Regular weight - 190gsm

QUALITY

Premium quality mercerized, double pre-shrunk, 100% cotton twill

COLOURS

Yellow, Orange

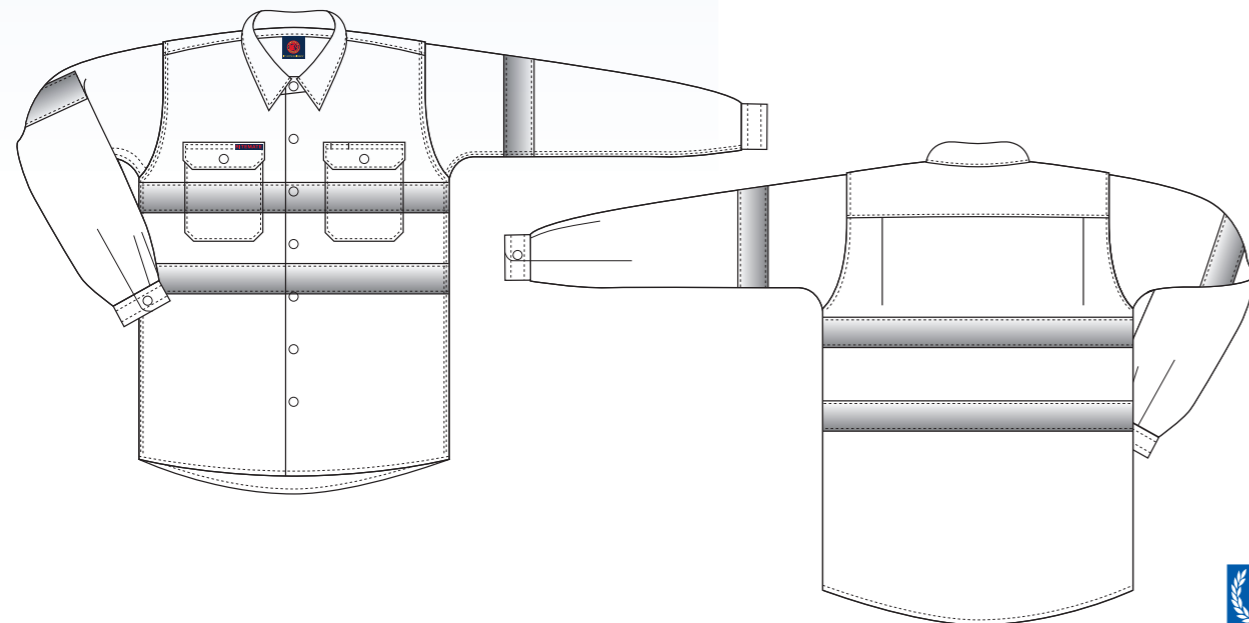

“IT’S GOTTA BE RITEMATE”



“IT’S GOTTA BE RITEMATE”

RM1000



Open front long sleeve shirt

FEATURES

- Superior garment assembly, twin needle stitching and bar tacks for extra strength
- UPF 50+ meets Australian standard AS/NZS 4399:1996
- Orange and yellow colour meets Australian standard AS/NZS 4602.1:2011 for high visibility day wear

SIZE

XS - 5XL

WEIGHT

Regular weight - 190gsm

QUALITY

Premium quality mercerized, double pre-shrunk, 100% cotton twill

COLOURS

Bottle, Khaki, Orange, Navy, Yellow

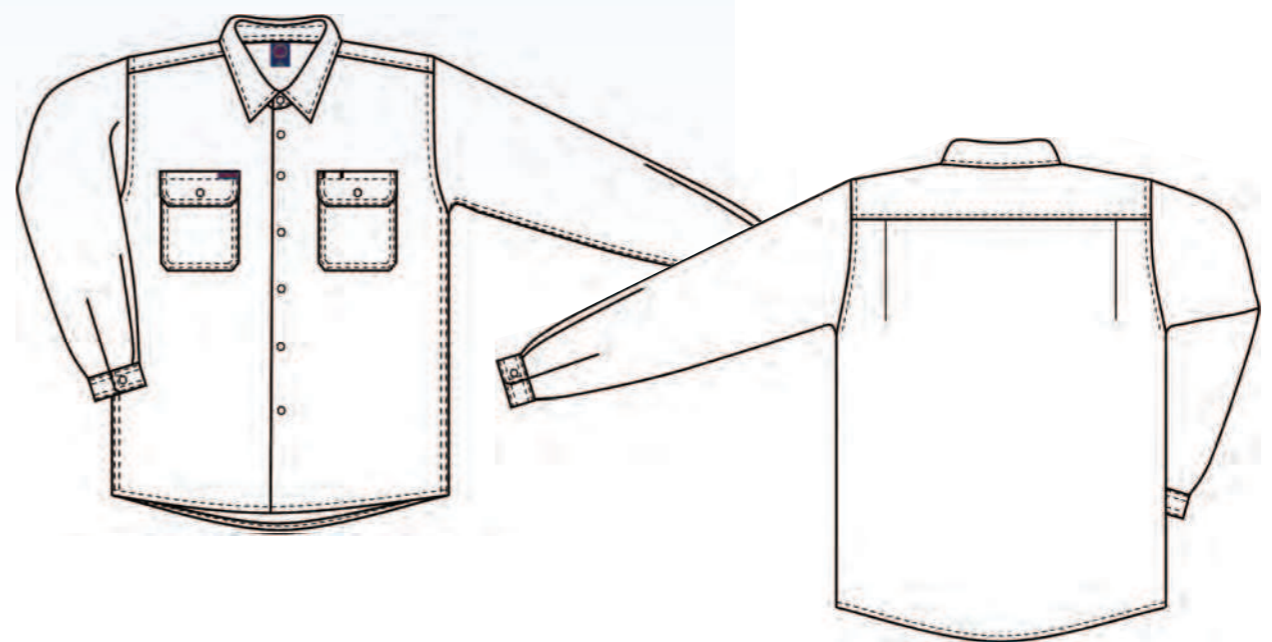

RM1000S

Open front short sleeve shirt

FEATURES

- Superior garment assembly, twin needle stitching and bar tacks for extra strength
- UPF 50+ meets Australian standard AS/NZS 4399:1996

SIZE

XS - 5XL

WEIGHT

Regular weight - 190gsm

QUALITY

Premium quality mercerized, double pre-shrunk, 100% cotton twill

COLOURS

Khaki, Navy, Bottle



RM100CF

Closed front long sleeve shirt

FEATURES

- Superior garment assembly, twin needle stitching and bar tacks for extra strength
- UPF 50+ meets Australian standard AS/NZS 4399:1996
- Orange colour meets Australian standard AS/NZS 4602.1:2011 for high visibility

SIZE

XS - 5XL

WEIGHT

Regular weight - 190gsm

QUALITY

Premium quality mercerized, double pre-shrunk, 100% cotton twill

COLOURS

Khaki, Navy, Bottle, Orange

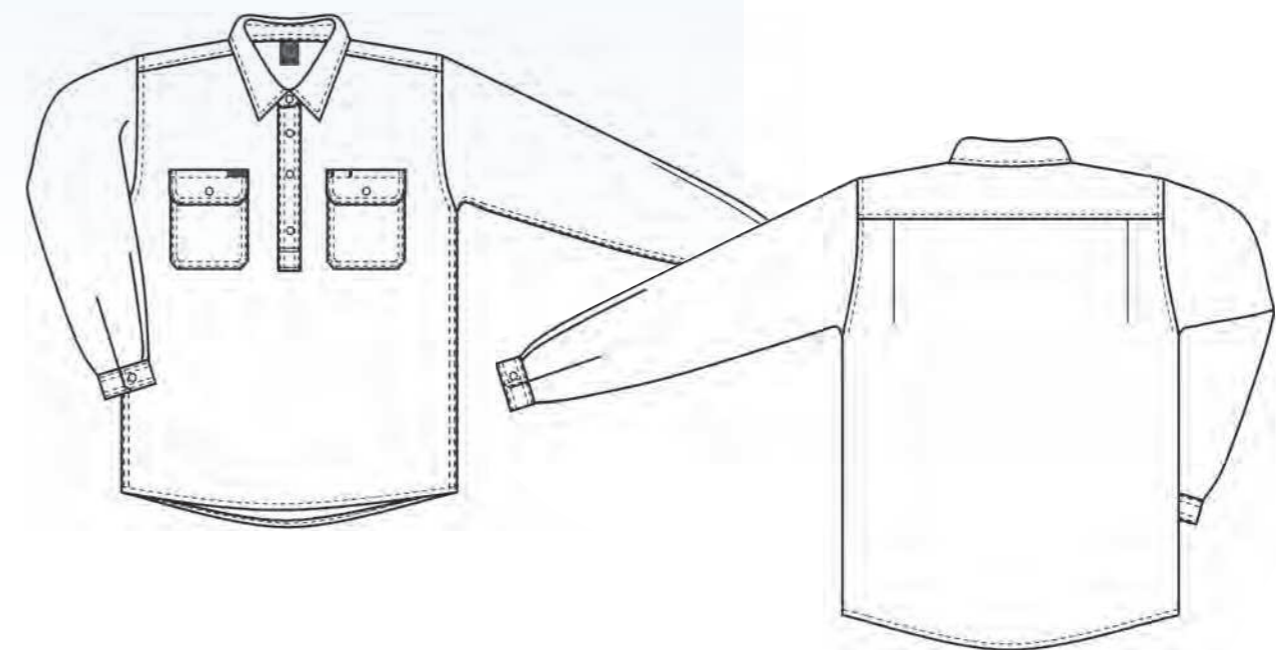

RM100CFS

Closed front short sleeve shirt

FEATURES

- Superior garment assembly, twin needle stitching and bar tacks for extra strength
- UPF 50+ meets Australian standard AS/NZS 4399:1996

SIZE

XS - 5XL

WEIGHT

Regular weight - 190gsm

QUALITY

Premium quality mercerized, double pre-shrunk, 100% cotton twill

COLOURS

Khaki, Navy, Bottle



RM208V2R

Ladies 2 tone vented light weight open front long sleeve shirt with 3M 8910 reflective tape

FEATURES

- Cotton mesh cooling vents located at underarm and shoulder positions
- Superior garment assembly, twin needle stitching and bar tacks for extra strength
- UPF 50+ meets Australian standard AS/NZS 4399:1996
- Meets Australian standard AS/NZS 1906.4:2010 & AS/NZS 4602.1:2011 for high visibility day/night wear
- Available in short sleeve upon request

SIZE

6 - 20

WEIGHT

Light weight - 150gsm

QUALITY

Premium quality mercerized, double pre-shrunk, 100% cotton twill

COLOURS

Yellow/Navy, Orange/Navy

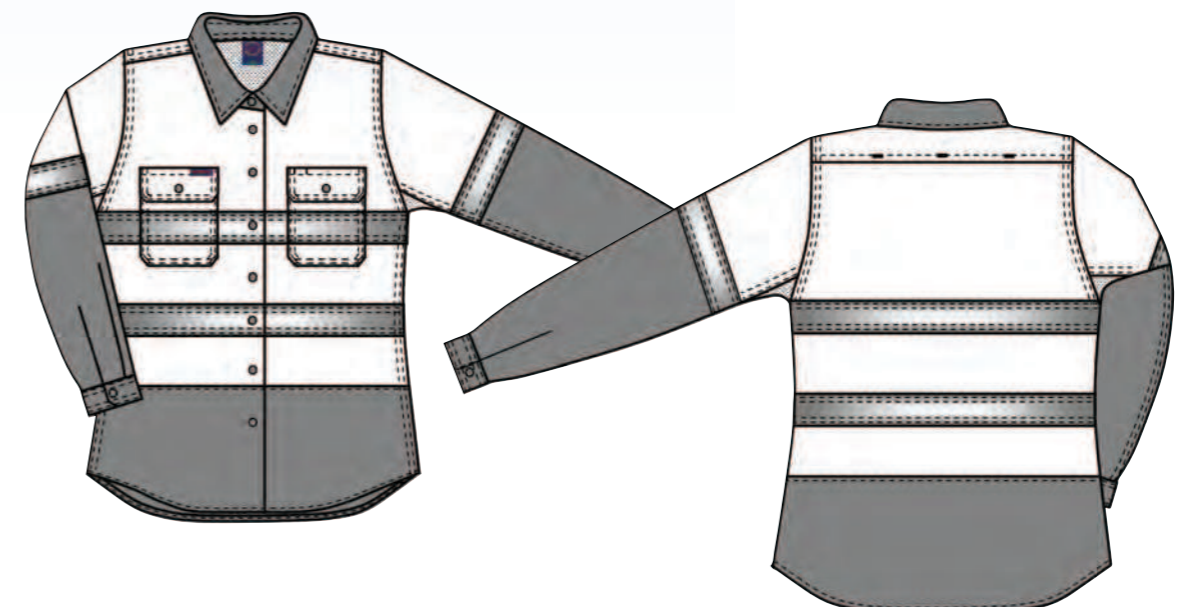

RM208V3R

Ladies vented light weight open front long sleeve shirt with 3M 8910 reflective tape

FEATURES

- Cotton mesh cooling vents located at underarm and shoulder positions
- Superior garment assembly, twin needle stitching and bar tacks for extra strength
- UPF 50+ meets Australian standard AS/NZS 4399:1996
- Meets Australian standard AS/NZS 1906.4:2010 & AS/NZS 4602.1:2011 for high visibility day/night wear
- Available in short sleeve upon request

SIZE

6 - 20

WEIGHT

Light weight - 150gsm

QUALITY

Premium quality mercerized, double pre-shrunk, 100% cotton twill

COLOURS

Orange

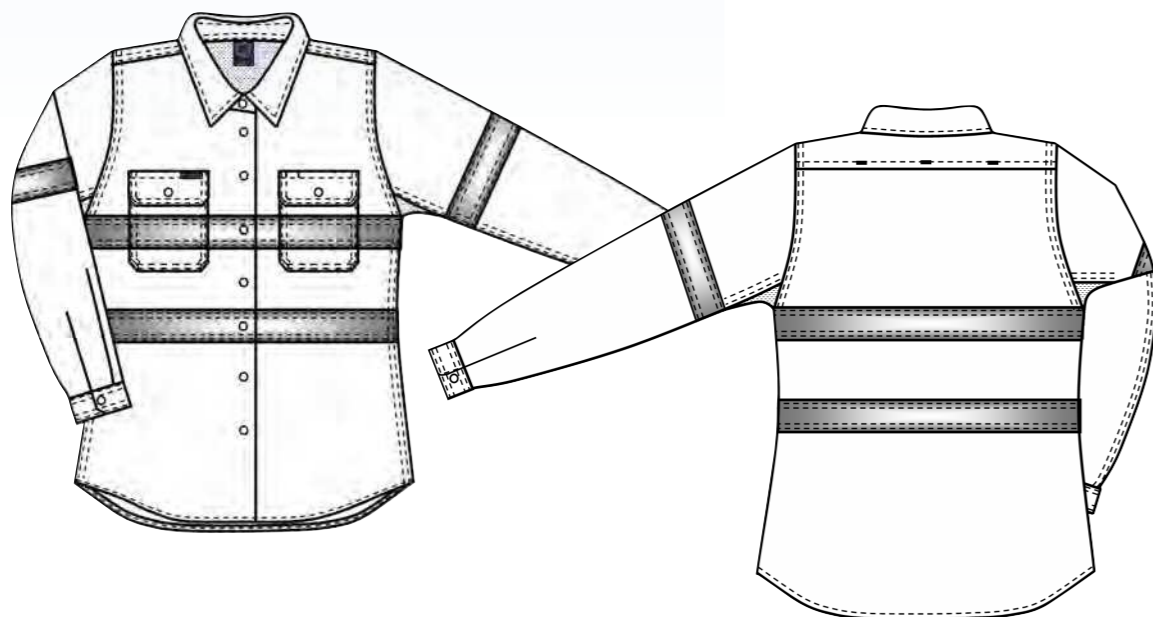

“IT’S GOTTA BE RITEMATE”



RM107V2

2 tone vented light weight open front long sleeve shirt

FEATURES

- Cotton mesh cooling vents located at underarm and shoulder positions
- Superior garment assembly, twin needle stitching and bar tacks for extra strength
- UPF 50+ meets Australian standard AS/NZS 4399:1996
- Meets Australian standard AS/NZS 4602.1:2011 for high visibility day wear

SIZE

XS - 5XL

WEIGHT

Light weight - 150gsm

QUALITY

Premium quality mercerized, double pre-shrunk, 100% cotton twill

COLOURS

Yellow/Navy, Orange/Navy

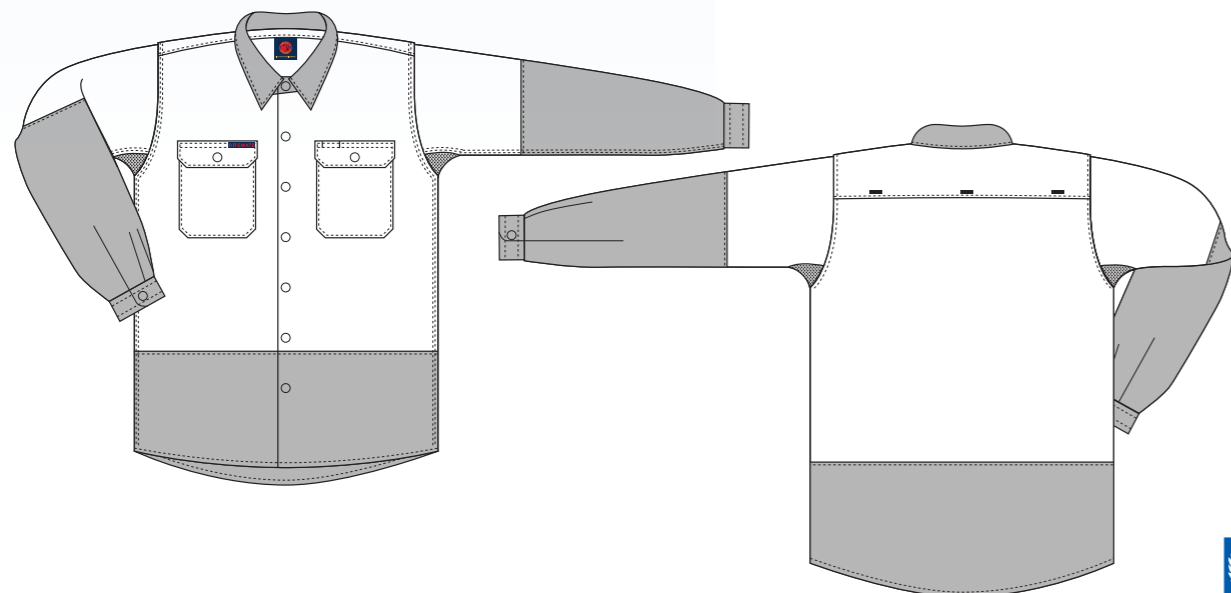

RM107V2S

2 tone vented light weight open front short sleeve shirt

FEATURES

- Cotton mesh cooling vents located at underarm and shoulder positions
- Superior garment assembly, twin needle stitching and bar tacks for extra strength
- UPF 50+ meets Australian standard AS/NZS 4399:1996
- Meets Australian standard AS/NZS 4602.1:2011 for high visibility day wear

SIZE

XS - 5XL

WEIGHT

Light weight - 150gsm

QUALITY

Premium quality mercerized, double pre-shrunk, 100% cotton twill

COLOURS

Yellow/Navy, Orange/Navy



RM107V2R

2 tone vented light weight open front long sleeve shirt with 3M 8910 reflective tape

FEATURES

- Cotton mesh cooling vents located at underarm and shoulder positions
- Superior garment assembly, twin needle stitching and bar tacks for extra strength
- UPF 50+ meets Australian standard AS/NZS 4399:1996
- Meets Australian standard AS/NZS 1906.4:2010 & AS/NZS 4602.1:2011 for high visibility day/night wear

SIZE

XS - 5XL

WEIGHT

Light weight - 150gsm

QUALITY

Premium quality mercerized, double pre-shrunk, 100% cotton twill

COLOURS

Yellow/Navy, Orange/Navy

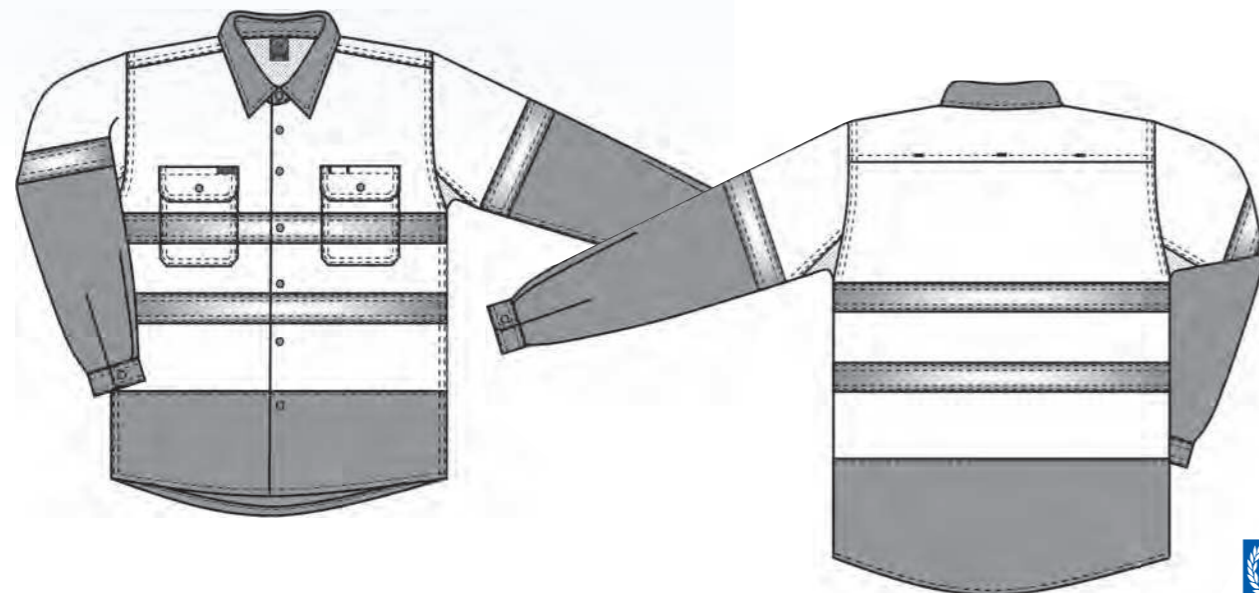

RM107V2RS

2 tone vented light weight open front short sleeve shirt with 3M 8910 reflective tape

FEATURES

- Cotton mesh cooling vents located at underarm and shoulder positions
- Superior garment assembly, twin needle stitching and bar tacks for extra strength
- UPF 50+ meets Australian standard AS/NZS 4399:1996
- Meets Australian standard AS/NZS 1906.4:2010 & AS/NZS 4602.1:2011 for high visibility day/night wear

SIZE

XS - 5XL

WEIGHT

Light weight - 150gsm

QUALITY

Premium quality mercerized, double pre-shrunk, 100% cotton twill

COLOURS

Yellow/Navy, Orange/Navy

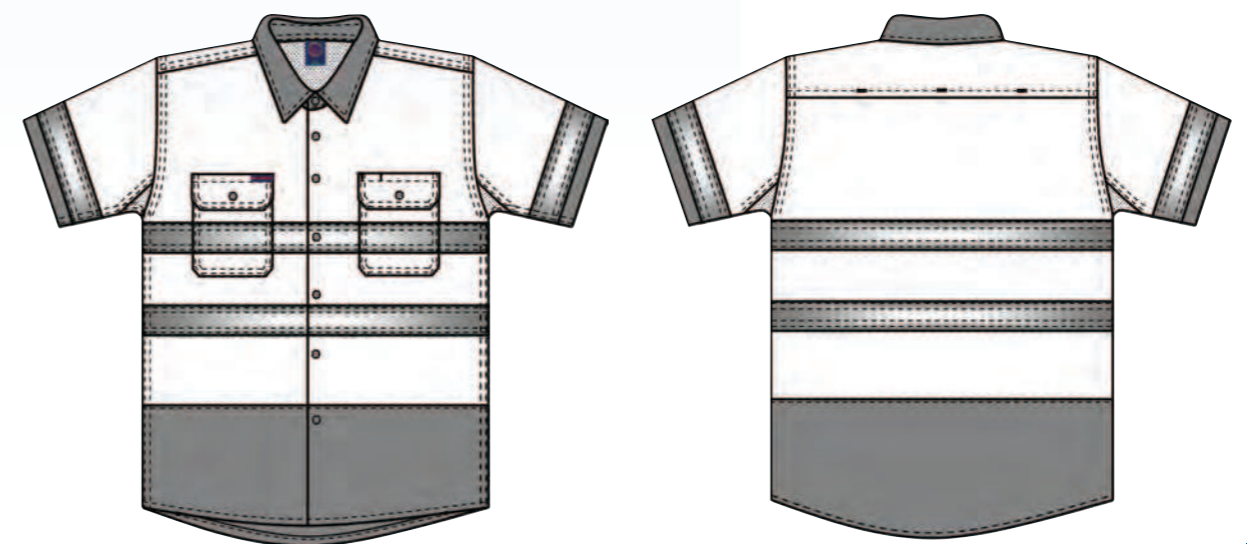

RM108V3

Vented light weight open front long sleeve shirt

FEATURES

- Cotton mesh cooling vents located at underarm and shoulder positions
- Superior garment assembly, twin needle stitching and bar tacks for extra strength
- UPF 50+ meets Australian standard AS/NZS 4399:1996
- Orange colour meets Australian standard AS/NZS 1906.4:2010 & AS/NZS 4602.1:2011 for high visibility day wear
- Available in short sleeve upon request

SIZE

XS - 5XL

WEIGHT

Light weight - 150gsm

QUALITY

Premium quality mercerized, double pre-shrunk, 100% cotton twill

COLOURS

Khaki, Navy, Orange

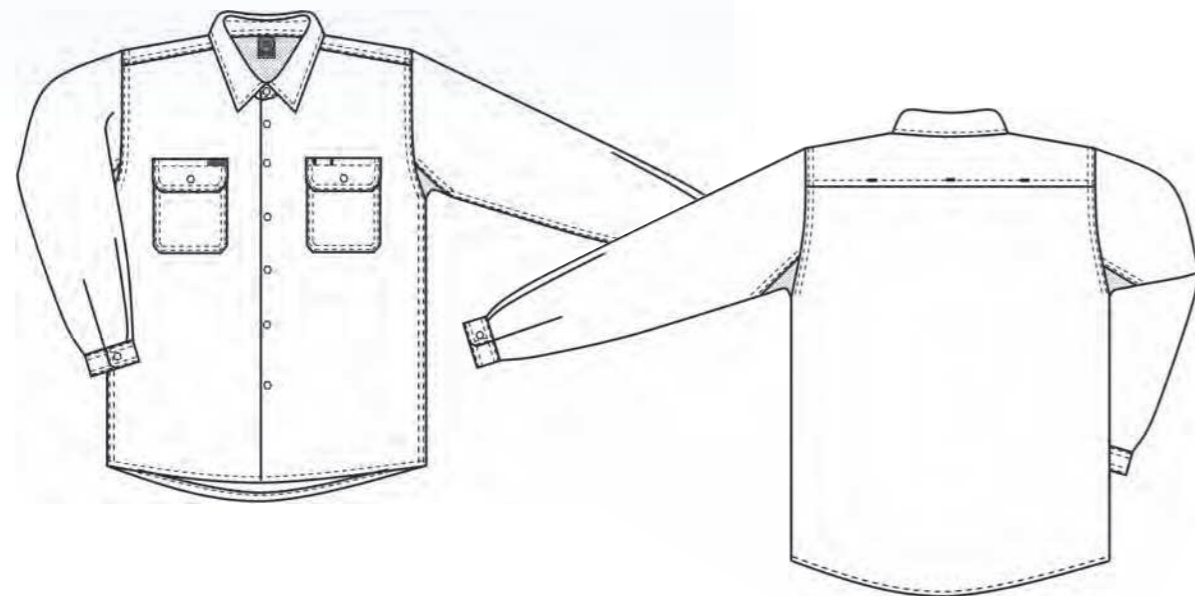

RM108V3R

Vented light weight open front long sleeve shirt with 3M 8910 reflective tape

FEATURES

- Cotton mesh cooling vents located at underarm and shoulder positions
- Superior garment assembly, twin needle stitching and bar tacks for extra strength
- UPF 50+ meets Australian standard AS/NZS 4399:1996
- Meets Australian standard AS/NZS 1906.4:2010 & AS/NZS 4602.1:2011 for high visibility day/night wear
- Available in short sleeve upon request

SIZE

XS - 5XL

WEIGHT

Light weight - 150gsm

QUALITY

Premium quality mercerized, double pre-shrunk, 100% cotton twill

COLOURS

Orange

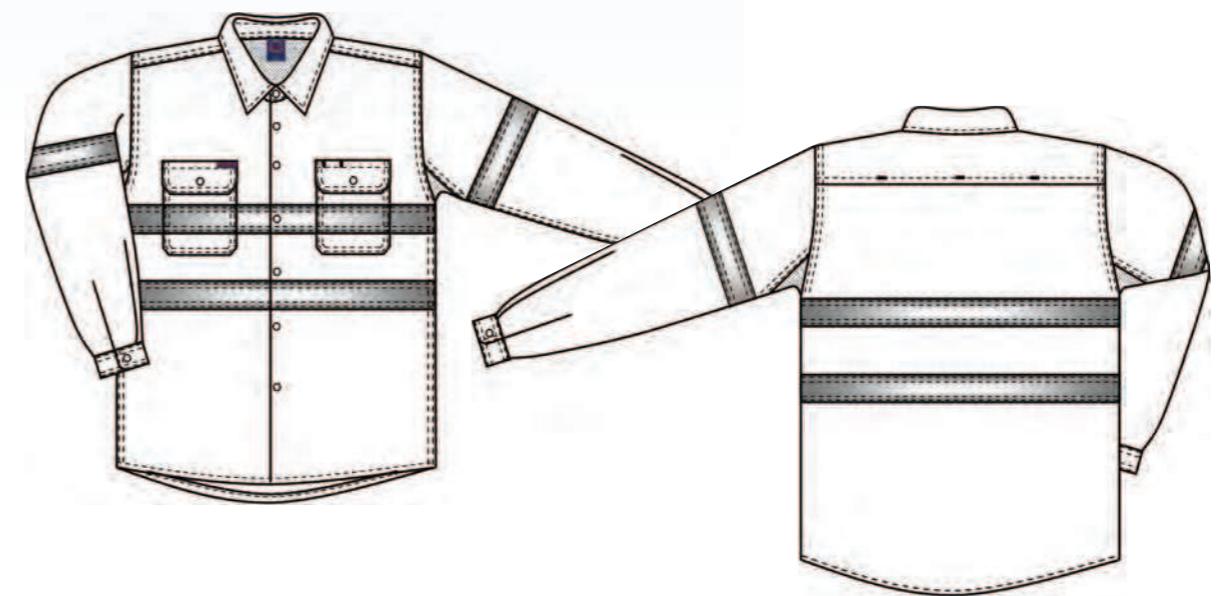

RM400CF

Children's Pilbara closed front long sleeve shirt

FEATURES

- Superior garment assembly, twin needle stitching and bar tacks for extra strength
- UPF 50+ meets Australian standard AS/NZS 4399:1996
- Designed for comfort

SIZE

0 - 14

WEIGHT

Light weight - 150gsm

QUALITY

Premium quality mercerized, double pre-shrunk, 100% cotton twill

COLOURS

Cobalt Blue, Stone, Hot Pink, Emerald, Purple, Red

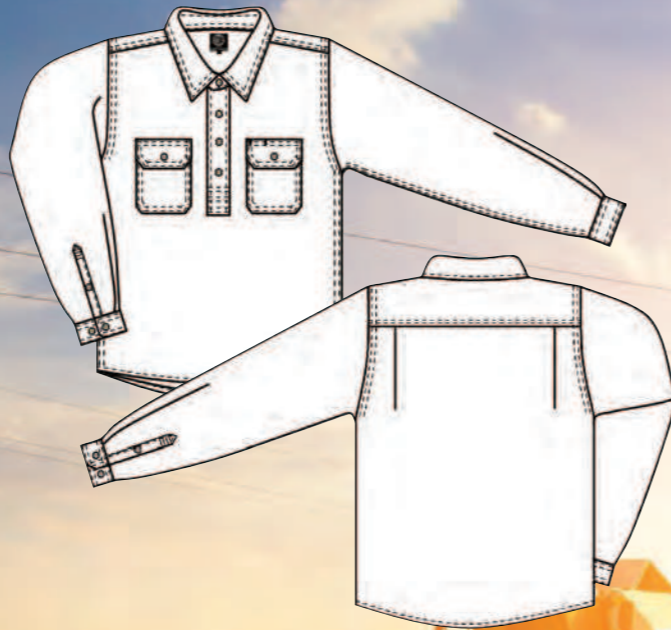

RM4050R

Children's 2 tone open front long sleeve shirt with reflective tape

FEATURES

- Superior garment assembly, twin needle stitching and bar tacks for extra strength
- UPF 50+ meets Australian standard AS/NZS 4399:1996

SIZE

0 - 14

WEIGHT

Light weight - 150gsm

QUALITY

Premium quality mercerized, double pre-shrunk, 100% cotton twill

COLOURS

Yellow/Navy, Orange/Navy, Pink/Navy, Blue/Navy

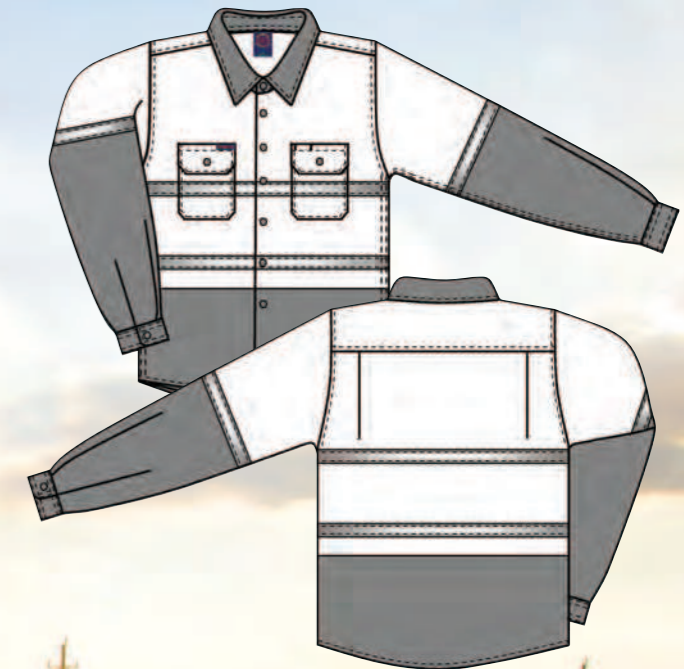

RM200CF

Pilbara men's closed front long sleeve shirt

FEATURES

- Superior garment assembly, twin needle stitching and bar tacks for extra strength
- UPF 50+ meets Australian standard AS/NZS 4399:1996
- Designed for comfort

SIZE

XS - 5XL

WEIGHT

Light weight - 150gsm

QUALITY

Premium quality mercerized, double pre-shrunk, 100% cotton twill

COLOURS

Bottle Green, Cobalt Blue, Red, Stone, Light Blue, Black, Emerald

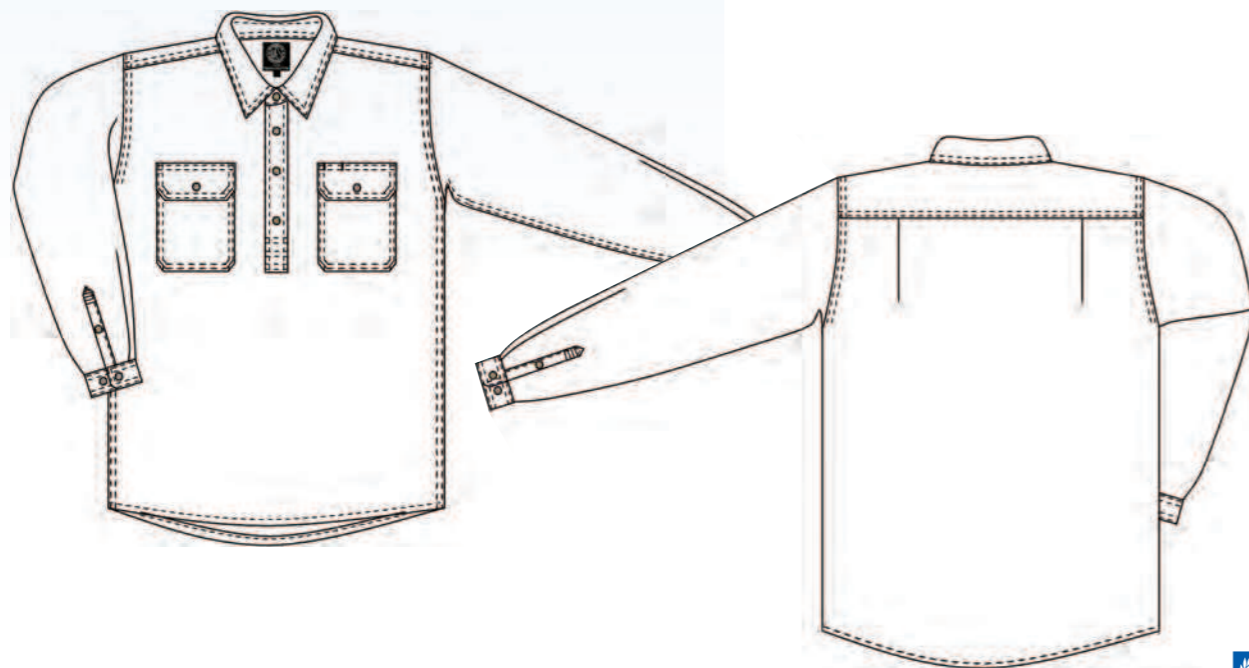

"IT'S GOTTA BE RITEMATE"



“IT’S GOTTA BE RITEMATE”

RM300CF



Pilbara ladies closed front long sleeve shirt

FEATURES

- Superior garment assembly, twin needle stitching and bar tacks for extra strength
- UPF 50+ meets Australian standard AS/NZS 4399:1996
- Designed for comfort

SIZE

6 - 20

WEIGHT

Light weight - 150gsm

QUALITY

Premium quality mercerized, double pre-shrunk, 100% cotton twill with soft hand feel

COLOURS

Bottle Green, Cobalt Blue, Purple, Hot Pink, Stone, Red, Emerald

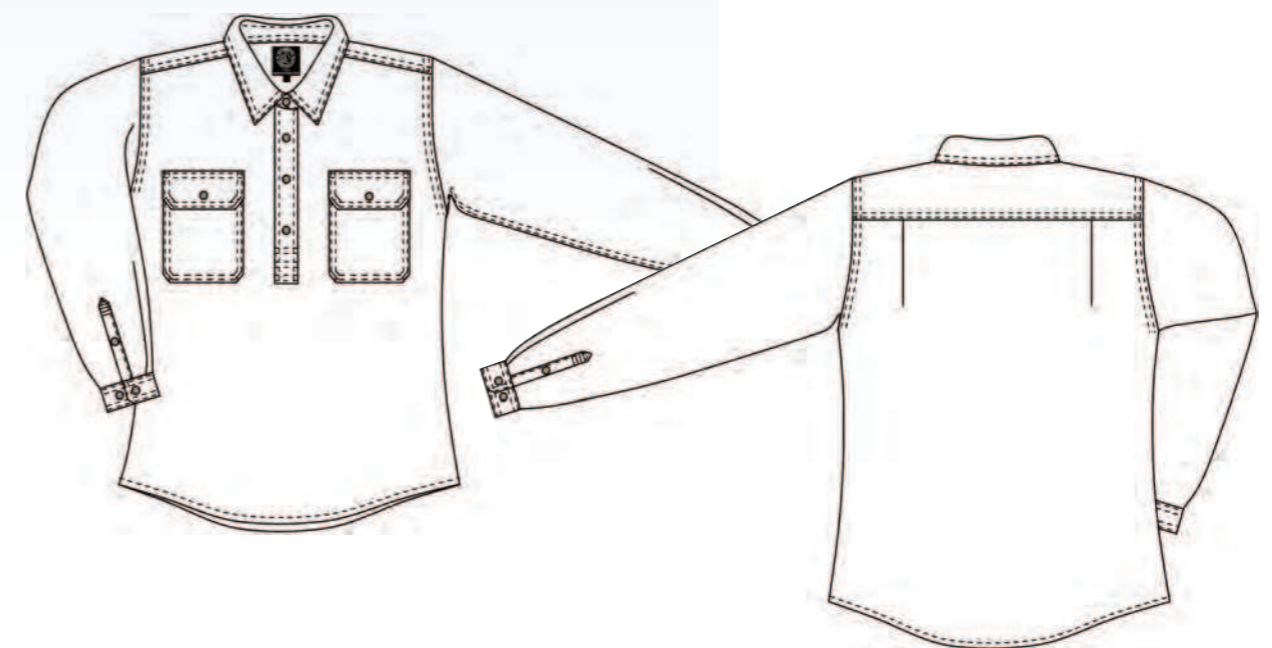

RM500BT

Pilbara men's open front long sleeve shirt

FEATURES

- Superior garment assembly, twin needle stitching and bar tacks for extra strength
- UPF 50+ meets Australian standard AS/NZS 4399:1996
- Designed for comfort

SIZE

XS - 5XL

WEIGHT

Light weight - 150gsm

QUALITY

Premium quality mercerized, double pre-shrunk, 100% cotton twill

COLOURS

Emerald, Cobalt Blue, Red, Stone, Light Blue, Black

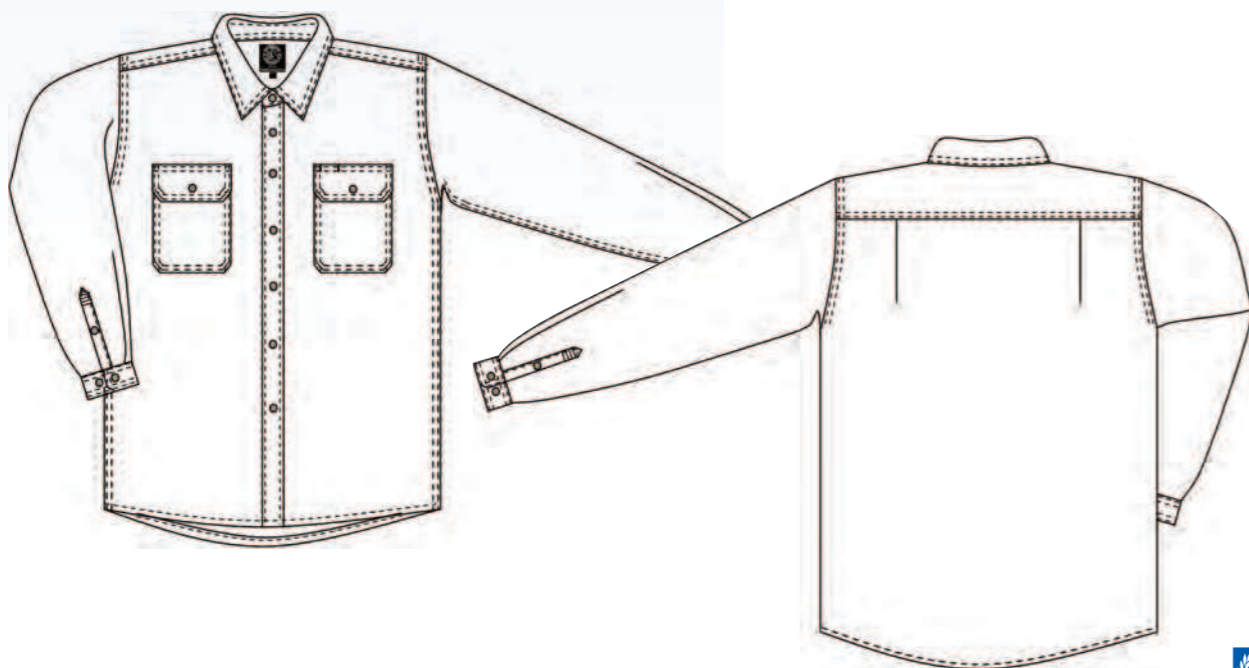

"IT'S GOTTA BE RITEMATE"



RM200CFS

Pilbara men's closed front short sleeve shirt

FEATURES

- Superior garment assembly, twin needle stitching and bar tacks for extra strength
- UPF 50+ meets Australian standard AS/NZS 4399:1996
- Designed for comfort

SIZE

XS - 5XL

WEIGHT

Light weight - 150gsm

QUALITY

Premium quality mercerized, double pre-shrunk, 100% cotton twill

COLOURS

Cobalt Blue, Red, Stone



RM500BTS

Pilbara men's open front short sleeve shirt

FEATURES

- Superior garment assembly, twin needle stitching and bar tacks for extra strength
- UPF 50+ meets Australian standard AS/NZS 4399:1996
- Designed for comfort

SIZE

XS - 5XL

WEIGHT

Light weight - 150gsm

QUALITY

Premium quality mercerized, double pre-shrunk, 100% cotton twill

COLOURS

Cobalt Blue, Red, Stone



“IT’S GOTTA BE RITEMATE”



RM123FCF

Closed front flannelette shirt

FEATURES

- UPF 50+ meets Australian standard AS/NZS 4399:1996

SIZE

XS - 5XL

WEIGHT

Regular weight - 160gsm

QUALITY

Premium Quality, Preshrunk 100% Cotton Flannelette

COLOURS

Available in assorted Colours

RM123QS

Open front quilted flannelette shirt

FEATURES

- Reinforced riveted metal clips
- UPF 50+ meets Australian standard AS/NZS 4399:1996

SIZE

XS - 5XL

WEIGHT

Regular weight - 160gsm

QUALITY

Premium Quality, Preshrunk 100% Cotton Flannelette

COLOURS

Available in assorted Colours



RM123V

Zip front quilted flannelette vest

FEATURES

- UPF 50+ meets Australian standard AS/NZS 4399:1996

SIZE

XS - 5XL

WEIGHT

Regular weight - 160gsm

QUALITY

Premium Quality, Preshrunk 100% Cotton Flannelette

COLOURS

Available in assorted Colours

RM123FOF

Open front flannelette shirt

FEATURES

- UPF 50+ meets Australian standard AS/NZS 4399:1996

SIZE

XS - 10XL

WEIGHT

Regular weight - 160gsm

QUALITY

Premium Quality, Preshrunk 100% Cotton Flannelette

COLOURS

Available in assorted Colours

RM1002

Belt loop drill trouser

FEATURES

- Superior garment assembly, twin needle stitching and bar tacks for extra strength
- UPF 50+ meets Australian standard AS/NZS 4399:1996
- Meets Australian standard AS/NZS 1906.4.2010 for high visibility night wear
- Quality YKK zippers Navy

SIZE

72R-112R, 87S-127S, 79L-94L

WEIGHT

Regular weight - 311gsm

QUALITY

Premium quality mercerized, double pre-shrunk, 100% cotton drill

COLOURS

Navy, Khaki, Bottle

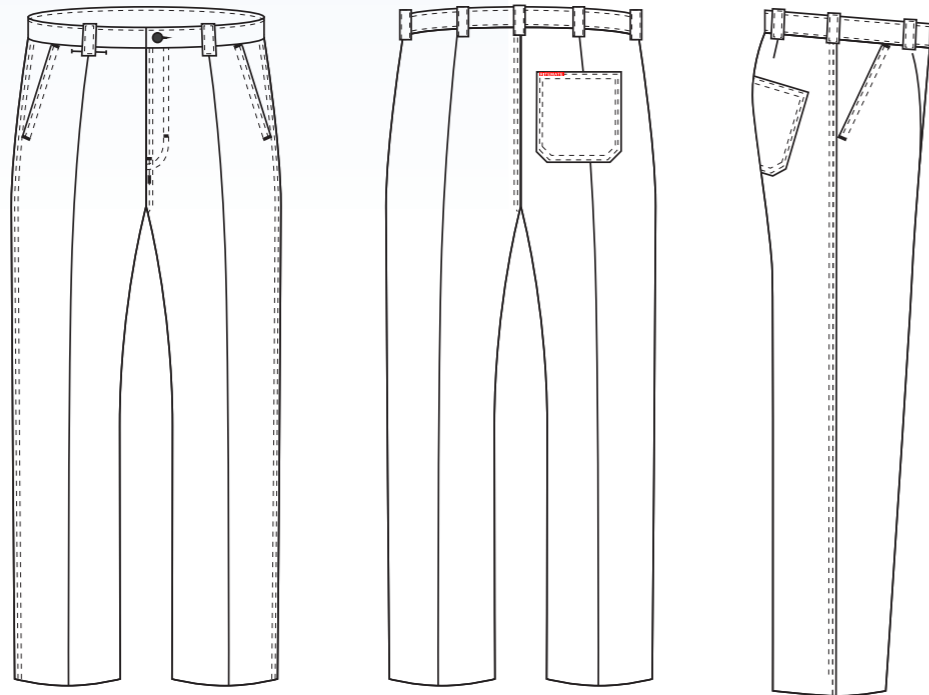

“IT’S GOTTA BE RITEMATE”



RM1002R

Belt loop drill trouser with 3M 8910 reflective tape

FEATURES

- Superior garment assembly, twin needle stitching and bar tacks for extra strength
- UPF 50+ meets Australian standard AS/NZS 4399:1996
- Meets Australian standard AS/NZS 1906.4.2010 for high visibility night wear
- Quality YKK zippers Navy

SIZE

72R-112R, 87S-127S, 79L-94L

WEIGHT

Regular weight - 311gsm

QUALITY

Premium quality mercerized, double pre-shrunk, 100% cotton drill

COLOURS

Navy

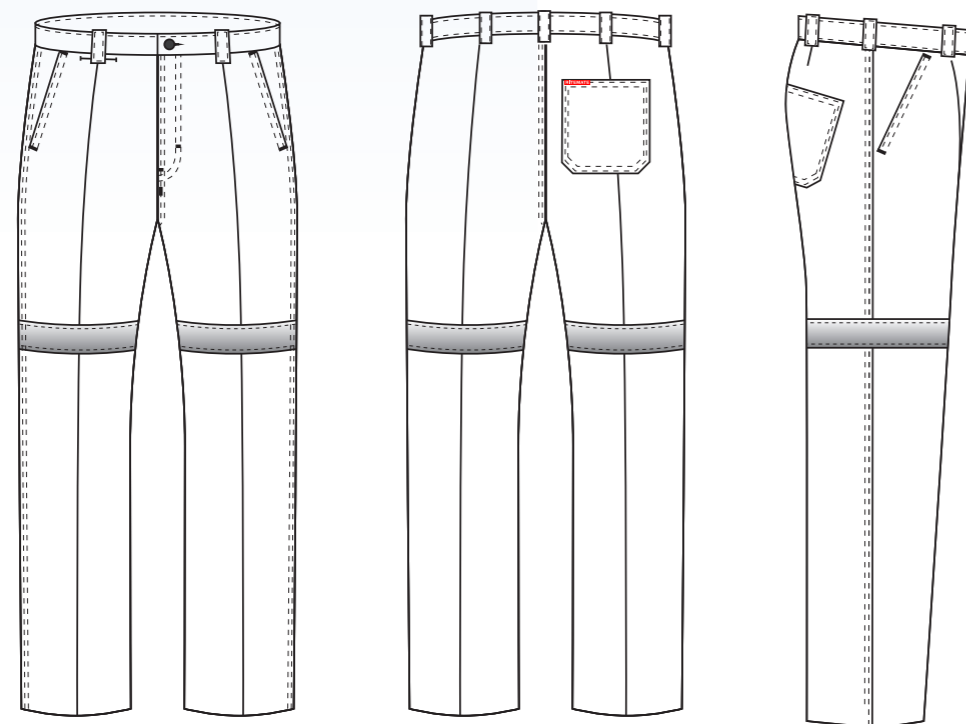

RM1004R

Cargo trouser with 3M 8910 reflective tape

FEATURES

- Superior garment assembly, twin needle stitching and bar tacks for extra strength
- UPF 50+ meets Australian standard AS/NZS 4399:1996
- Meets Australian standard AS/NZS 1906.4.2010 for high visibility night wear
- Quality YKK zippers Navy

SIZE

72R-112R, 87S-127S, 79L-94L

WEIGHT

Regular weight - 311gsm

QUALITY

Premium quality mercerized, double pre-shrunk, 100% cotton drill

COLOURS

Navy

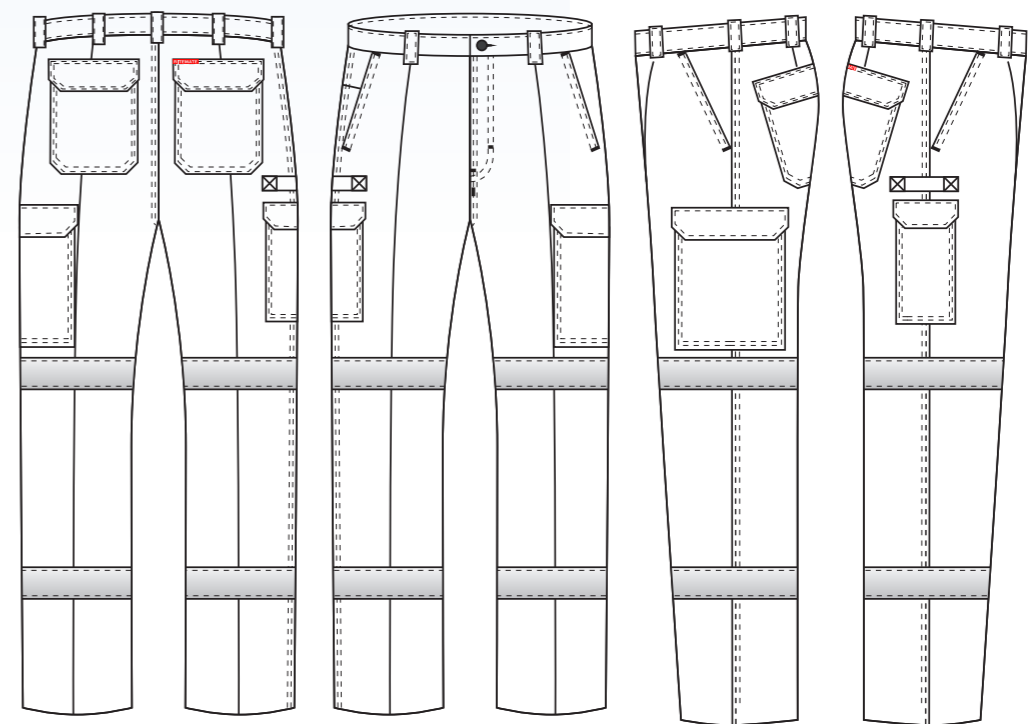

“IT’S GOTTA BE RITEMATE”

RM1004



Cargo trouser

FEATURES

- Superior garment assembly, twin needle stitching and bar tacks for extra strength
- UPF 50+ meets Australian standard AS/NZS 4399:1996
- Quality YKK zippers Navy

SIZE

72R-112R, 87S-127S, 79L-94L

WEIGHT

Regular weight - 311gsm

QUALITY

Premium quality mercerized, double pre-shrunk, 100% cotton drill

COLOURS

Black, Bottle, Khaki, Navy

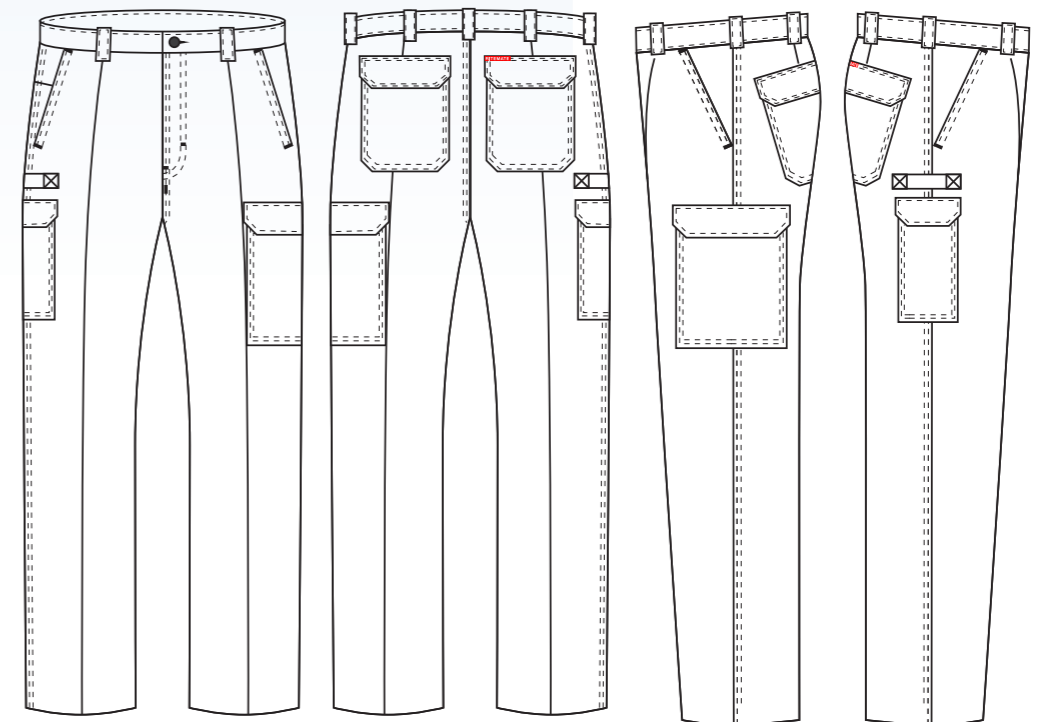

RM1002S

Belt loop and side tab combo short

FEATURES

- Superior garment assembly, twin needle stitching and bar tacks for extra strength
- UPF 50+ meets Australian standard AS/NZS 4399:1996
- Quality YKK zippers Navy

SIZE

72 - 127

WEIGHT

Regular weight - 311gsm

QUALITY

Premium quality mercerized, double pre-shrunk, 100% cotton drill

COLOURS

Bottle, Khaki, Navy

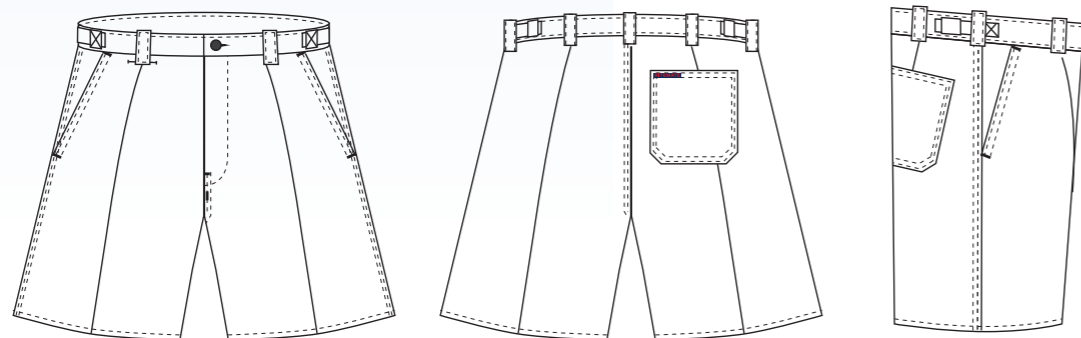

RM1004S

Cargo short

FEATURES

- Superior garment assembly, twin needle stitching and bar tacks for extra strength
- UPF 50+ meets Australian standard AS/NZS 4399:1996
- Quality YKK zippers Navy

SIZE

72 - 127

WEIGHT

Regular weight - 311gsm

QUALITY

Premium quality mercerized, double pre-shrunk, 100% cotton drill

COLOURS

Black, Bottle, Khaki, Navy

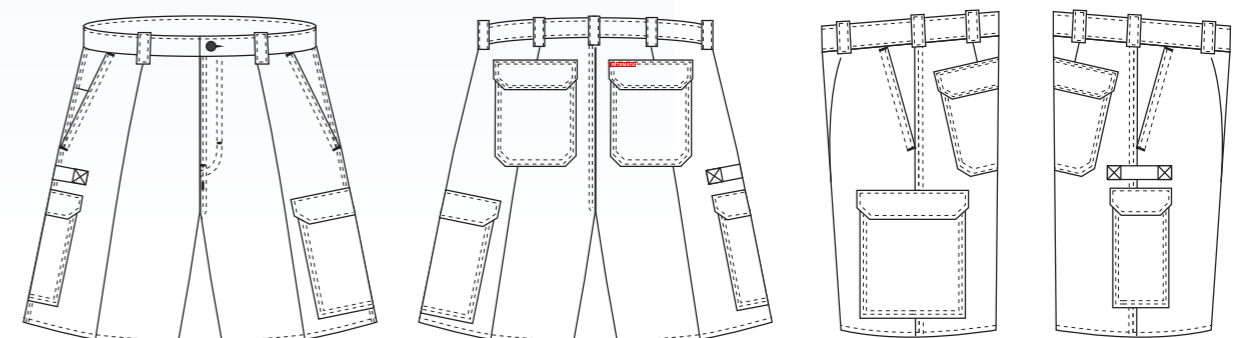

RM4040

Light weight 4040 cargo short – unisex short

FEATURES

- Soft handle garment wash
- Streamline inverted cargo pockets
- Superior garment assembly, twin needle stitching and bar tacks for extra strength
- UPF 50+ meets Australian standard AS/NZS 4399:1996
- Quality YKK zippers

SIZE

Men's sizes 72 - 127
Ladies sizes 8 - 24

WEIGHT

Light weight - 190gsm

QUALITY

Premium quality mercerized, double pre-shrunk, 100% cotton drill

COLOURS

Black, Navy, Khaki

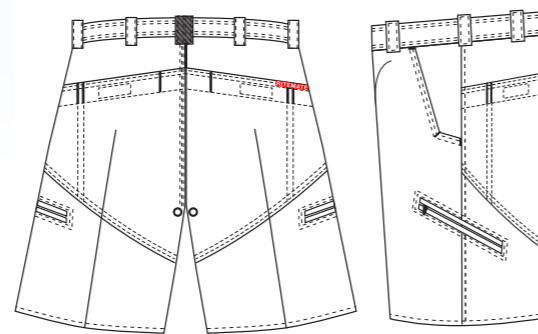
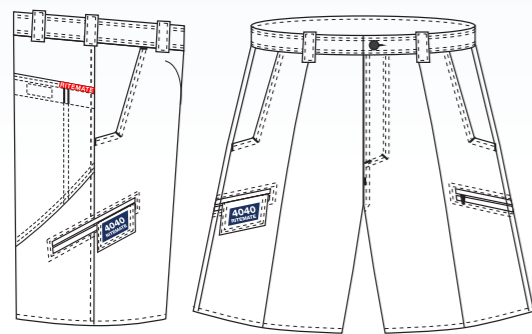

RM8080

Light weight 8080 cargo trouser – unisex trouser

FEATURES

- Soft handle garment wash
- Streamline inverted cargo pockets
- Superior garment assembly, twin needle stitching and bar tacks for extra strength
- UPF 50+ meets Australian standard AS/NZS 4399:1996
- Quality YKK zippers

SIZE

Men's sizes 72R-112R, 87S-127S, 79L-94L
Ladies sizes 8 - 24

WEIGHT

Light weight - 190gsm

QUALITY

Premium quality mercerized, double pre-shrunk, 100% cotton drill

COLOURS

Black, Navy, Khaki

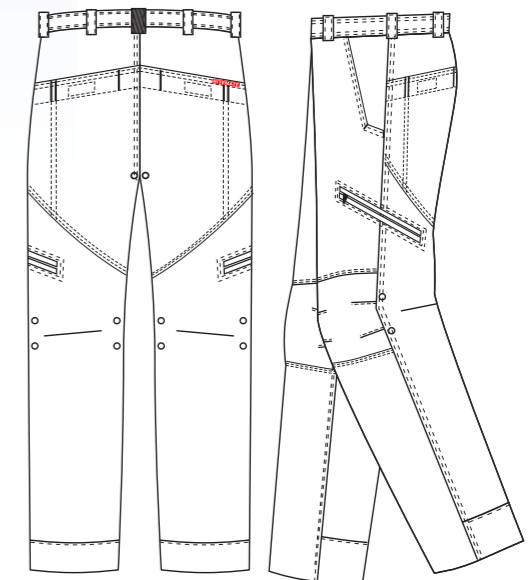
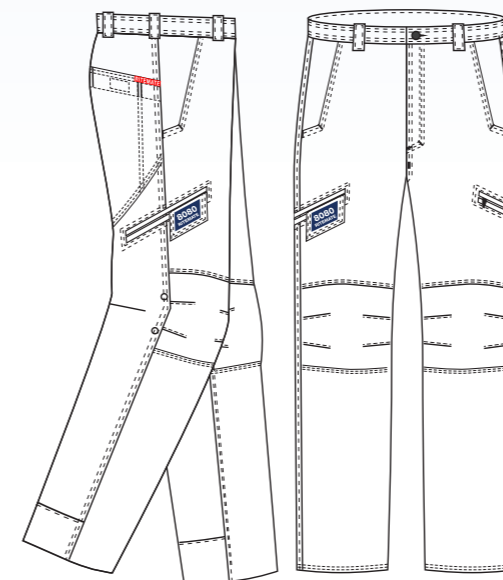

RM33EWLS

Elastic waist long leg short

FEATURES

- Superior garment assembly, twin needle stitching and bar tacks for extra strength
- UPF 50+ meets Australian standard AS/NZS 4399:1996
- Quality YKK zippers Navy

SIZE

72 - 127

WEIGHT

Regular weight - 311gsm

QUALITY

Premium quality mercerized, double pre-shrunk, 100% cotton drill

COLOURS

Black, Navy

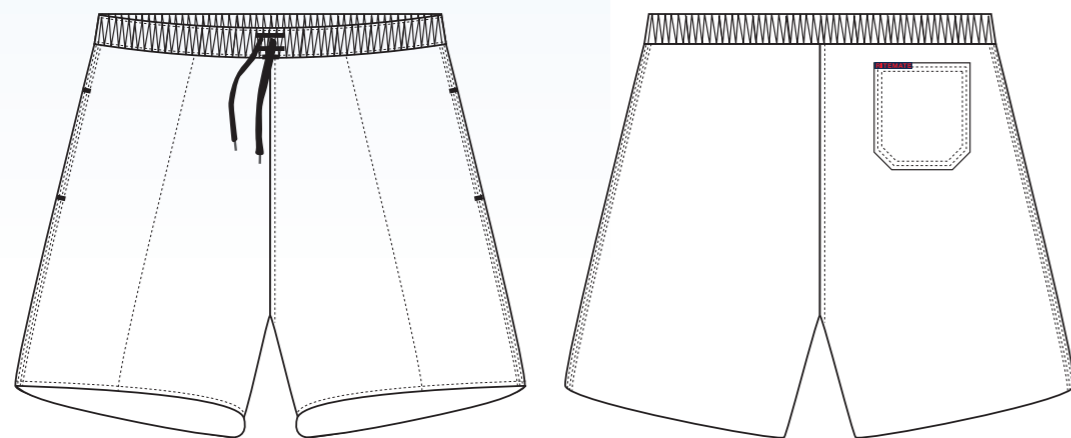

“IT’S GOTTA BE RITEMATE”



RM301EWS

Elastic waist rugby short

FEATURES

- Superior garment assembly, twin needle stitching and bar tacks for extra strength
- UPF 50+ meets Australian standard AS/NZS 4399:1996

SIZE

72 - 127

WEIGHT

Regular weight - 311gsm

QUALITY

Premium quality mercerized, double pre-shrunk, 100% cotton drill

COLOURS

Bottle, Black, White, Navy

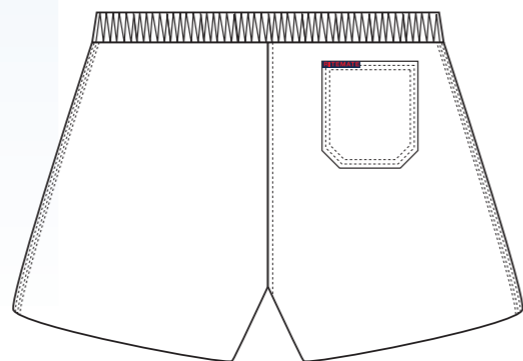
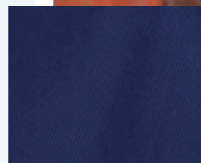
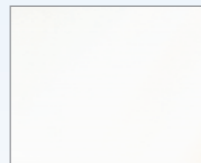

RM1007

Mid weight cargo trouser

FEATURES

- Heel Protection, comfort waist band, heavy duty double pocket lining, engineered fit, air vented, extra pockets and utility loops.
- Superior garment assembly, twin needle stitching and bar tacks for extra strength
- UPF 50+ meets Australian standard AS/NZS 4399:1996
- Quality YKK zippers

SIZE

72R-112R, 87S-127S, 79L-94L

WEIGHT

Mid weight - 270gsm

QUALITY

Premium quality mercerized, double pre-shrunk, 100% cotton drill

COLOURS

Navy

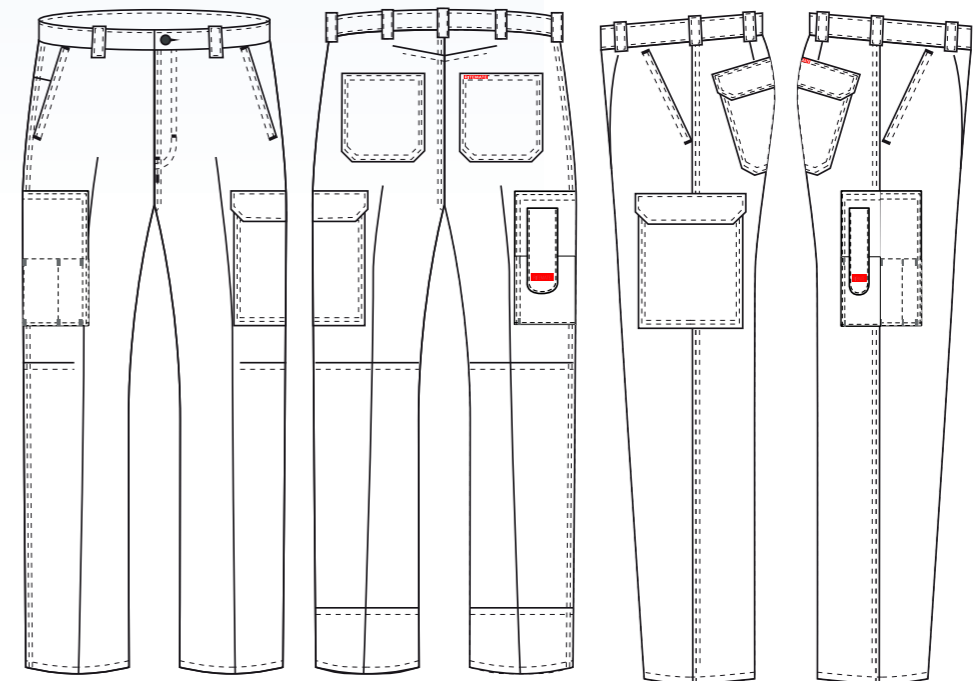

RM1008M

Coverall

FEATURES

- Superior garment assembly, twin needle stitching and bar tacks for extra strength
- UPF 50+ meets Australian standard AS/NZS 4399:1996
- Quality YKK zippers

SIZE

72R-107R, 92S-127S

WEIGHT

Mid weight - 270gsm

QUALITY

Premium quality mercerized, double pre-shrunk, 100% cotton drill

COLOURS

Navy

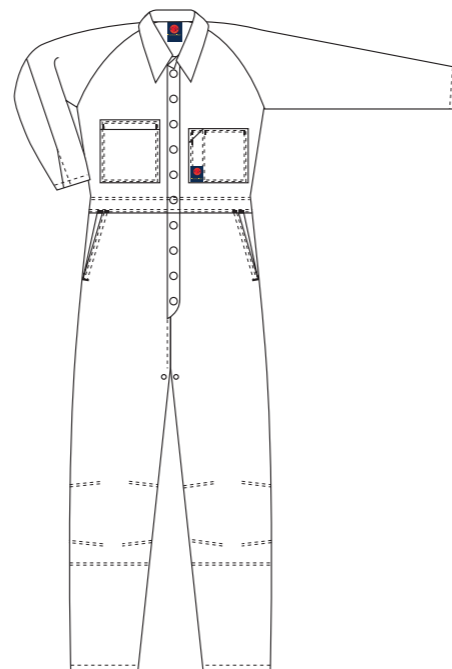
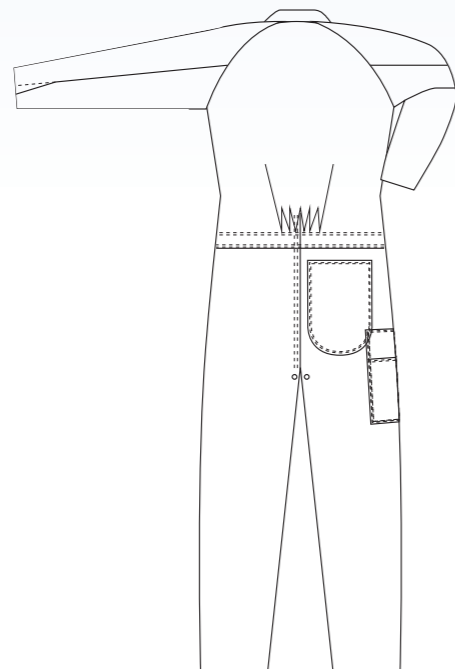

RM908CR

2 tone coverall with 3M 8910 reflective tape

FEATURES

- Superior garment assembly, twin needle stitching and bar tacks for extra strength
- Meets Australian standard AS/NZS 1906.4:2010 & AS/NZS 4602.1:2011 for high visibility day/night wear
- UPF 50+ meets Australian standard AS/NZS 4399:1996
- Quality riveted press studs
- Quality YKK zippers

SIZE

77R-112R, 87S-127S

WEIGHT

Regular weight - 311gsm

QUALITY

Premium quality mercerized, double pre-shrunk, 100% cotton drill

COLOURS

Yellow/Navy, Orange/Navy

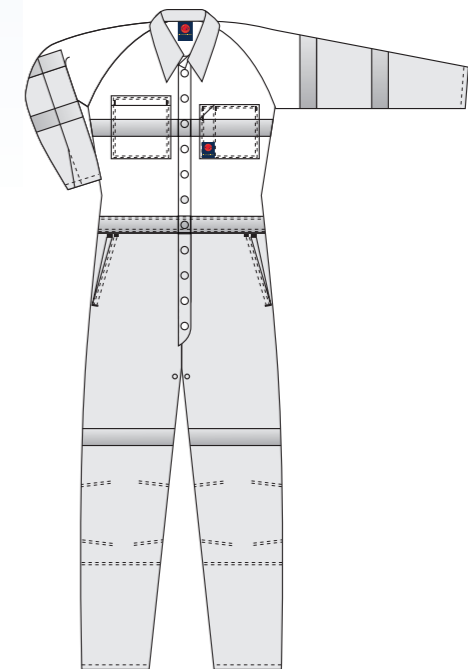
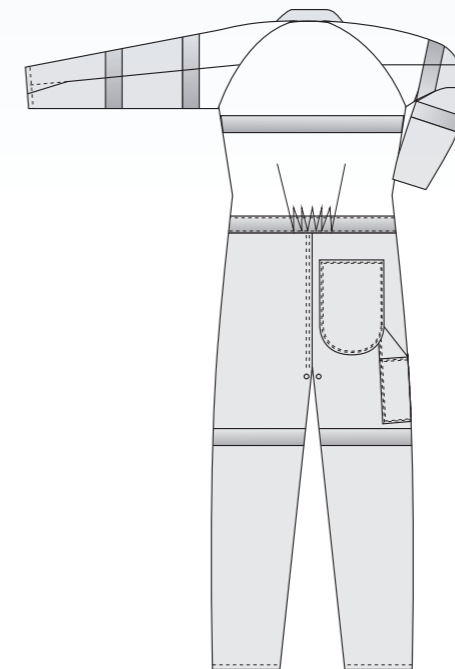

RM909AR

2 tone action back overall with 3M 8910 reflective tape

FEATURES

- Superior garment assembly, twin needle stitching and bar tacks for extra strength
- Quality riveted press studs
- Quality YKK zippers
- UPF 50+ meets Australian standard AS/NZS 4399:1996

SIZE

77R-112R, 87S-127S

WEIGHT

Regular weight - 311gsm

QUALITY

Premium quality mercerized, double pre-shrunk, 100% cotton drill

COLOURS

Orange/Navy, Yellow/Navy

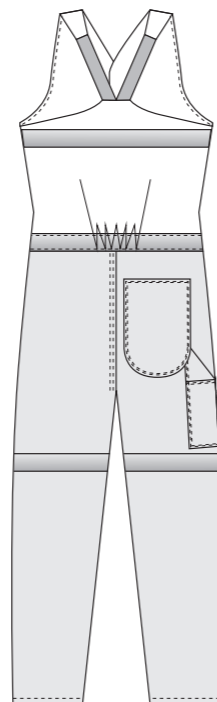
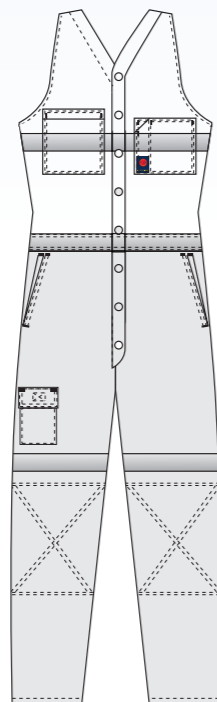

RM411CP

CORDURA® cargo trouser

FEATURES

- Strategically position anti-abrasive CORDURA® panels for extra strength and dura-bility
- Superior garment assembly, triple needle stitching and contrast bar tacks for extra strength
- UPF 50+ meets Australian standard AS/NZS 4399:1996
- Quality YKK zippers

SIZE

72R-112R, 87S-127S, 79L-94L

WEIGHT

Regular weight - 345gsm

QUALITY

Premium quality silicon washed pre-shrunk, 100% cotton duck weave

COLOURS

Khaki, Navy

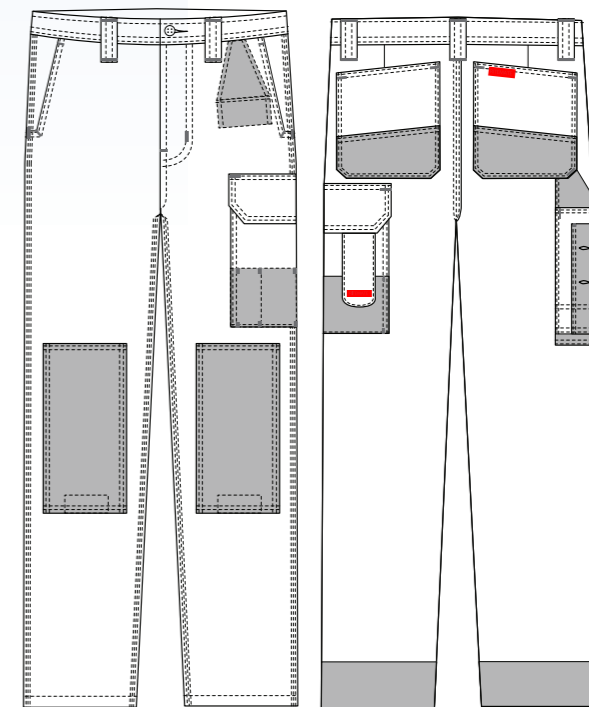

What is CORDURA® fabric?

CORDURA® fabric is what many of the most respected brands, retailers and military organisations around the world use when they need to make a product that is durable, versatile and reliable. Constructed using high tenacity fibre technology, weight for weight CORDURA® fabric is exceptionally durable. The fact is, no matter the application CORDURA® fabric is "Best in Class". More importantly, CORDURA® fabric is stringently tested before it can earn the CORDURA® brand name. CORDURA® is available in a wide range of weights, constructions and textures. All in all, CORDURA® fabrics make strong, long-lasting products even tougher in several categories from outdoor gear and military uniforms to WORKWEAR.



RM411CS

CORDURA® cargo short

FEATURES

- Strategically position anti-abrasive CORDURA® panels for extra strength and dura-bility
- Superior garment assembly, triple needle stitching and contrast bar tacks for extra strength
- UPF 50+ meets Australian standard AS/NZS 4399:1996
- Quality YKK zippers

SIZE

77 - 127

WEIGHT

Regular weight - 345gsm

QUALITY

Premium quality silicon washed pre-shrunk, 100% cotton duck weave

COLOURS

Khaki, Navy

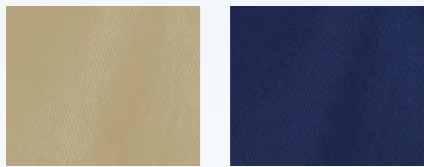

What is CORDURA® fabric?

CORDURA® fabric is what many of the most respected brands, retailers and military organisations around the world use when they need to make a product that is durable, versatile and reliable. Constructed using high tenacity fibre technology, weight for weight CORDURA® fabric is exceptionally durable. The fact is, no matter the application CORDURA® fabric is "Best in Class". More importantly, CORDURA® fabric is stringently tested before it can earn the CORDURA® brand name. CORDURA® is available in a wide range of weights, constructions and textures. All in all, CORDURA® fabrics make strong, long-lasting products even tougher in several categories from outdoor gear and military uniforms to WORKWEAR.

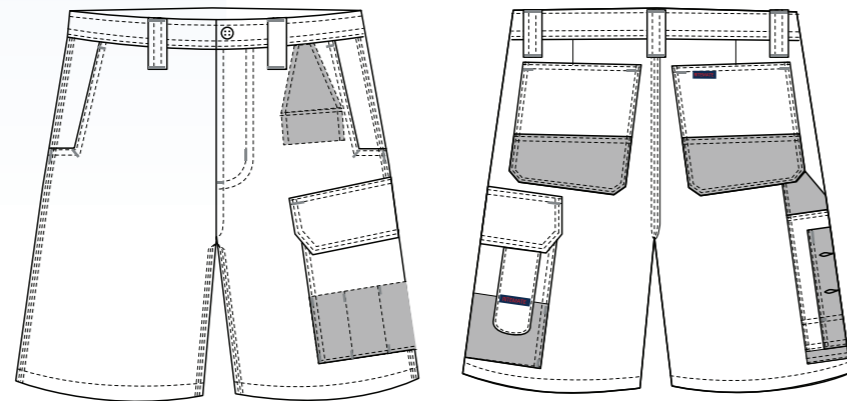

"IT'S GOTTA BE RITEMATE"



RM106DJ

Denim jeans

FEATURES

- Superior garment assembly, twin needle stitching, rivets and bar tacks for extra strength
- UPF 50+ meets Australian standard AS/NZS 4399:1996
- Quality YKK Zippers

SIZE

72R-112R, 87S-127S, 79L-94L

WEIGHT

14.5 OZ stone wash denim

COLOURS

Blue

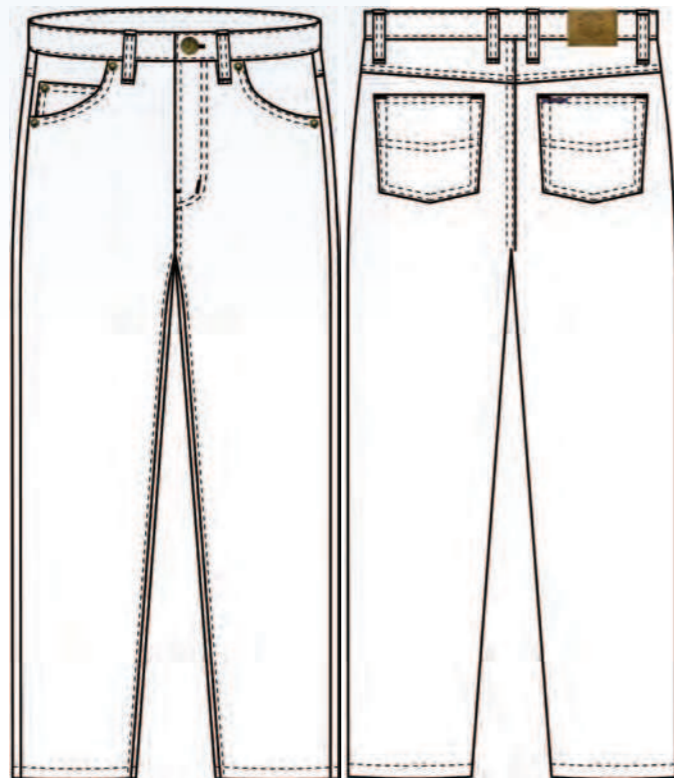

RM106DJR

Denim jeans with 3M 8910 reflective tape

FEATURES

- Superior garment assembly, twin needle stitching, rivets and bar tacks for extra strength
- UPF 50+ meets Australian standard AS/NZS 4399:1996
- Meets Australian standard AS/NZS 1906.4.2010 for high visibility night wear
- Quality YKK Zippers

SIZE

72R-112R, 87S-127S, 79L-94L

WEIGHT

14.5 OZ stone wash denim

COLOURS

Blue

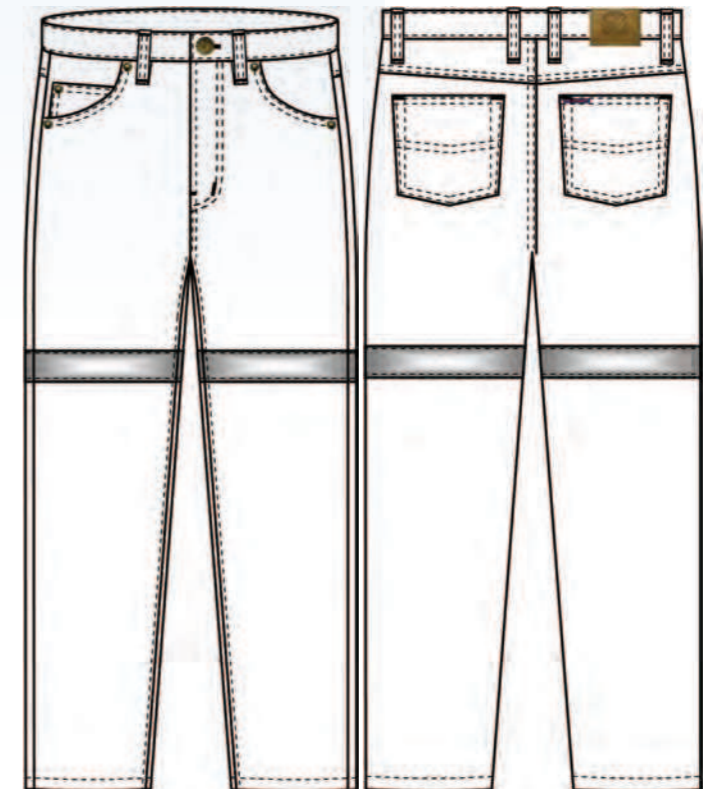

RM110SD

Stretch denim jeans

FEATURES

- Superior garment assembly, twin needle stitching, rivets and bar tacks for extra strength
- UPF 50+ meets Australian standard AS/NZS 4399:1996
- Quality YKK Zippers

SIZE

72R-112R, 87S-127S, 79L-94L

WEIGHT

13.75 OZ stone wash denim

COLOURS

Blue

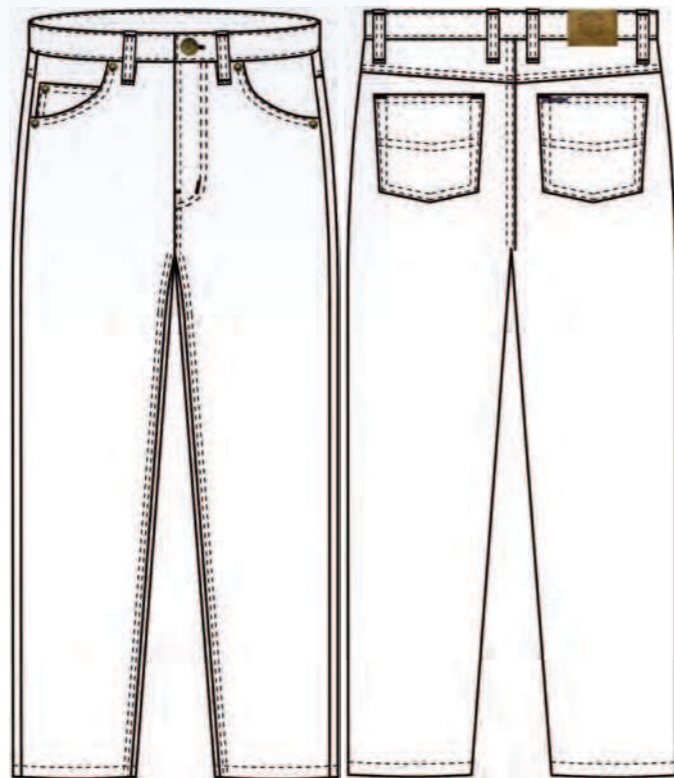

RM110SDR

Stretch denim jeans with 3M 8910 reflective tape

FEATURES

- Superior garment assembly, twin needle stitching and bar tacks for extra strength
- UPF 50+ meets Australian standard AS/NZS 4399:1996
- Quality YKK zippers
- Meets Australian standard AS/NZS 1906.4.2010 for high visibility night wear

SIZE

72R-112R, 87S-127S, 79L-94L

WEIGHT

13.75 OZ stone wash denim

COLOURS

Blue

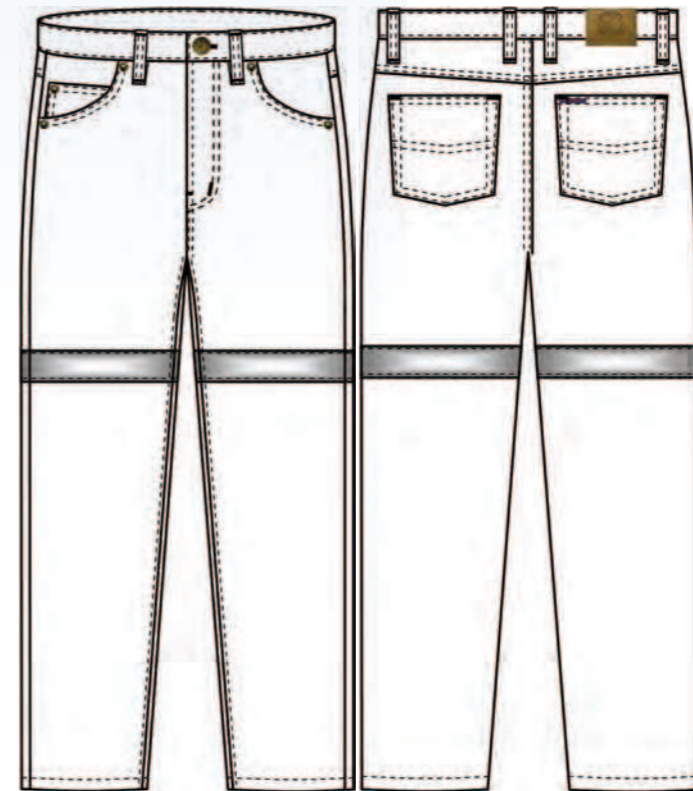

“IT’S GOTTA BE RITEMATE”

RM112TSD



Denim Trucker Short (Jean Short)

FEATURES

- Superior garment assembly, twin needle stitching, rivets and bar tacks for extra strength
- Stretch denim for easy wear and comfortable fit
- Quality YKK Zippers

SIZE

77 - 127

WEIGHT

13.75 OZ stone wash stretch denim

COLOURS

Blue

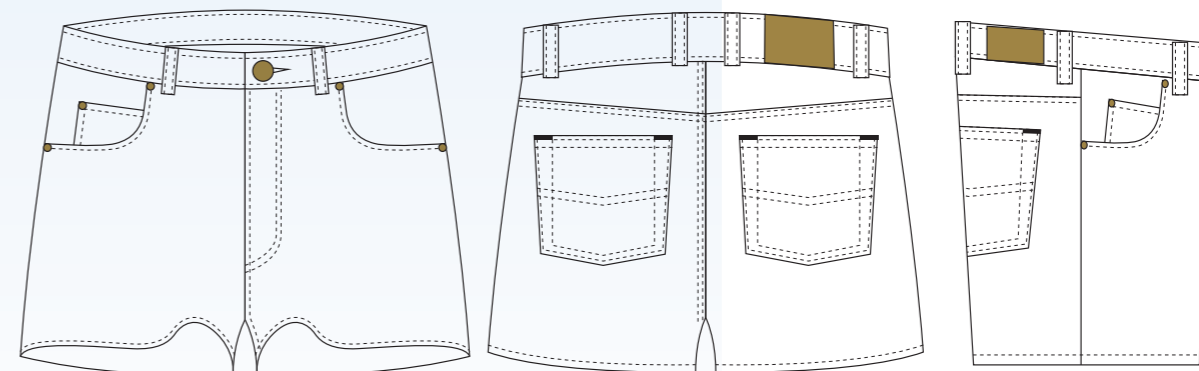

RM220LSD

Ladies stretch denim jeans

FEATURES

- Superior garment assembly, twin needle stitching, rivets and bar tacks for extra strength
- UPF 50+ meets Australian standard AS/NZS 4399:1996
- Quality YKK Zippers

SIZE

6 - 24 medium rise fit

WEIGHT

13.75 OZ stone wash denim

COLOURS

Blue

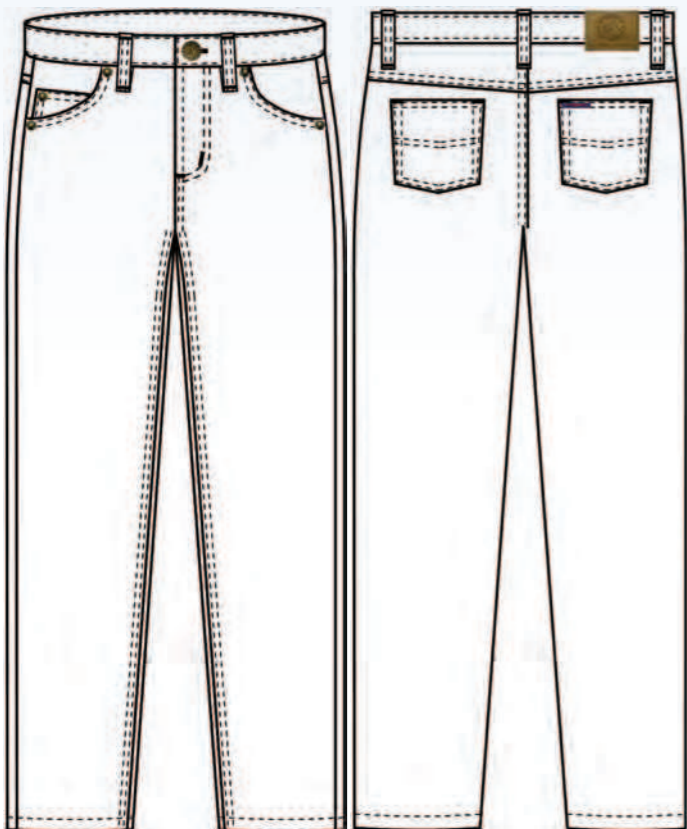

RM220LSDR

Ladies stretch denim jeans with 3M 8910 reflective tape

FEATURES

- Superior garment assembly, twin needle stitching, rivets and bar tacks for extra strength
- UPF 50+ meets Australian standard AS/NZS 4399:1996
- Quality YKK Zippers

SIZE

6 - 24 medium rise fit

WEIGHT

13.75 OZ stone wash denim

COLOURS

Blue

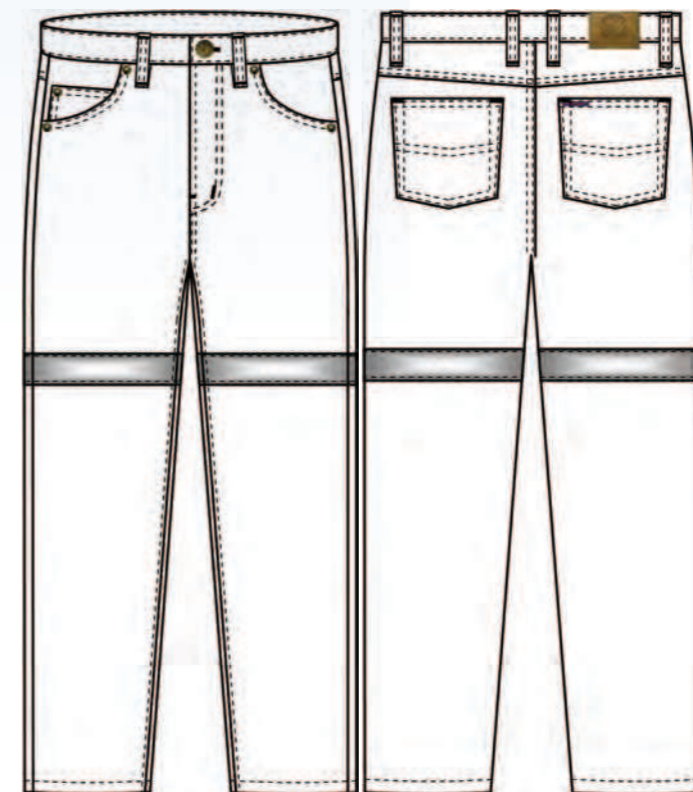

RM2346

Hi viz long sleeve polo shirt

FEATURES

- Our comfort plus fabric is constructed with a polyester face for superior luminosity and has a cotton back to make the fabric cool and comfortable to wear
- UPF 50+ meets Australian standard AS/NZS 4399:1996
- Meets Australian standard AS/NZS 4602.1:2011 for high visibility day wear

SIZE

XS - 4XL

WEIGHT

185gsm

COLOURS

Yellow/Bottle, Yellow/Navy, Orange/Navy

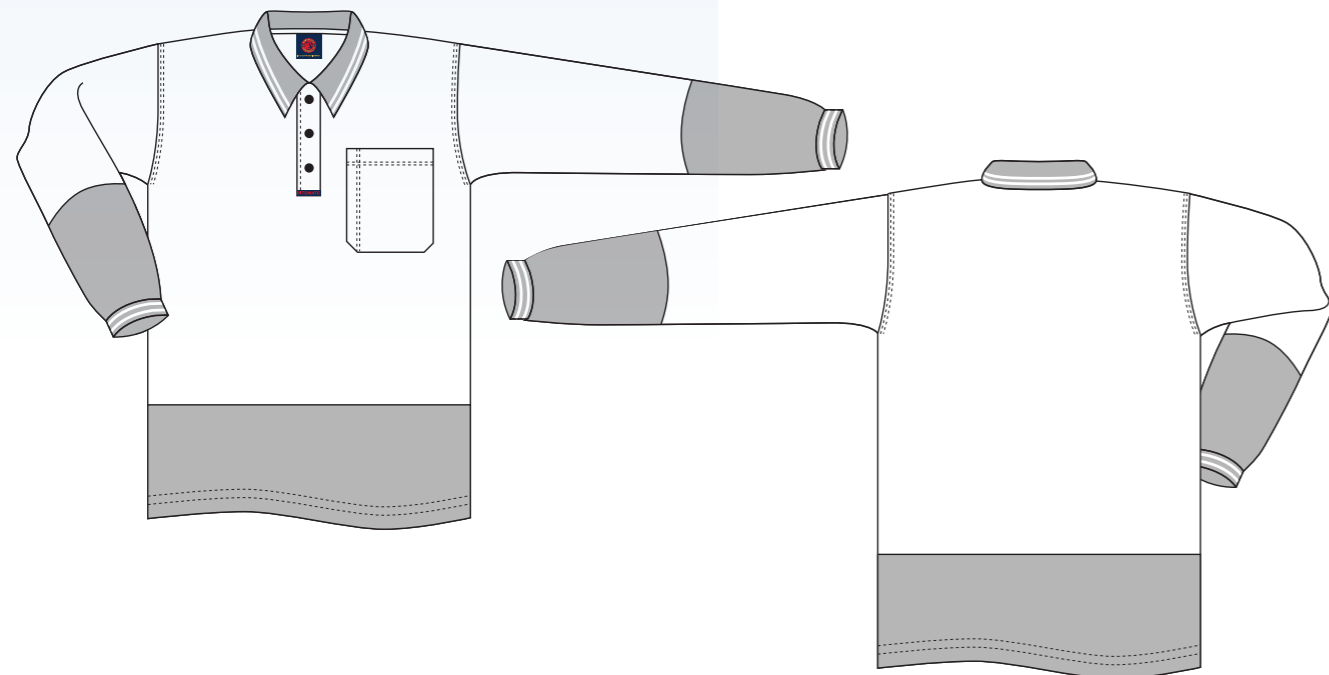

RM2346S

Hi viz short sleeve polo shirt

FEATURES

- Our comfort plus fabric is constructed with a polyester face for superior luminosity and has a cotton back to make the fabric cool and comfortable to wear
- UPF 50+ meets Australian standard AS/NZS 4399:1996
- Meets Australian standard AS/NZS 4602.1:2011 for high visibility day wear

SIZE

XS - 4XL

WEIGHT

185gsm

COLOURS

Yellow/Bottle, Yellow/Navy, Orange/Navy

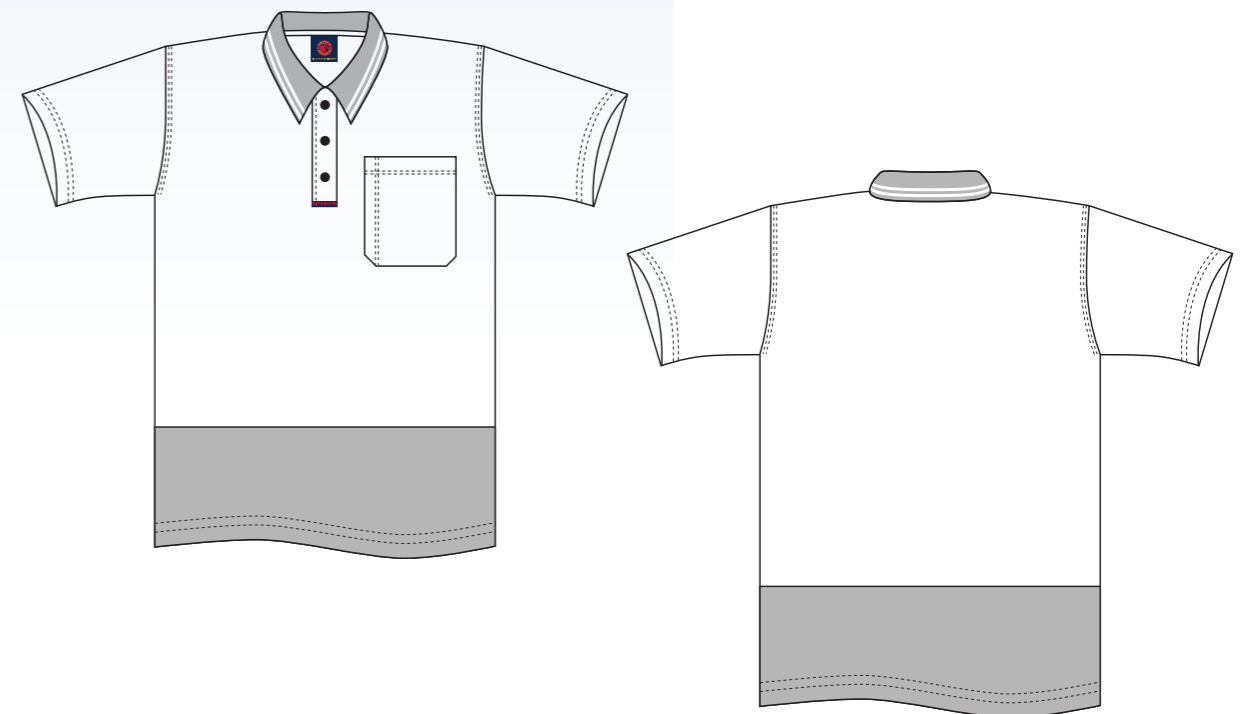

RM4245

Hi viz vest

FEATURES

- Extra strength velcro and binding
- Meets Australian standard AS/NZS 4602.1:2011 for high visibility day wear

SIZE

XS - 4XL

WEIGHT

120gsm

QUALITY

100% polyester for superior colour luminosity

COLOURS

Orange, Yellow

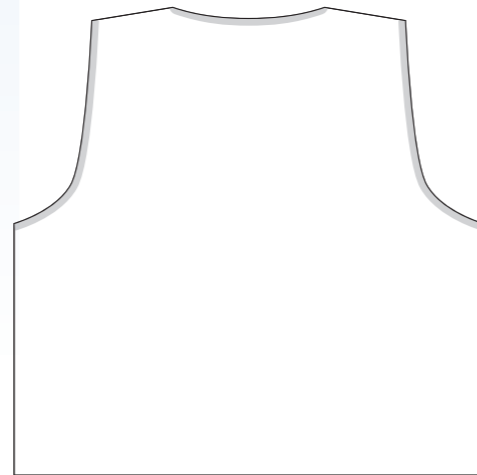
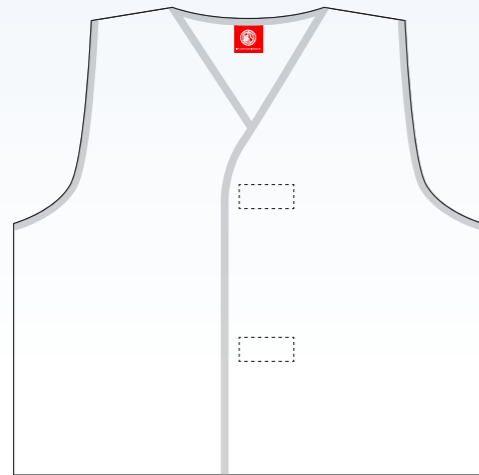

RM4245T

Day/night vest with 3M reflective tape

FEATURES

- Extra strength velcro and binding
- Meets Australian standard AS/NZS 1906.4:2010 & AS/NZS 4602.1:2011 for high visibility day/night wear

SIZE

XS - 4XL

WEIGHT

120gsm

QUALITY

100% polyester for superior colour luminosity

COLOURS

Orange, Yellow, Pink (for night use only)

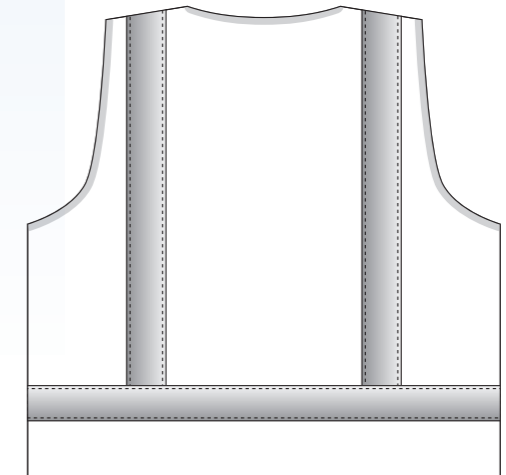
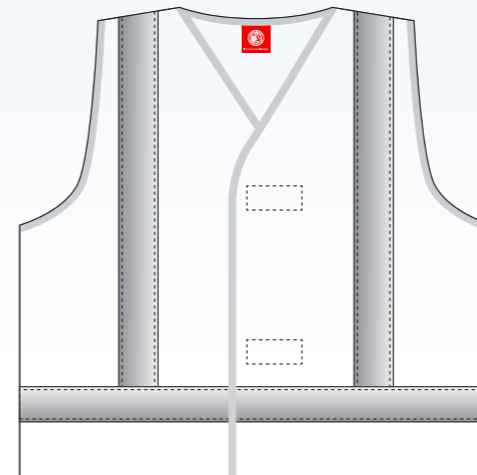

RM6012

Half zip fleecy pullover

FEATURES

- Pen pocket on upper sleeve
- Zip pull
- UPF 50+ meets Australian standard AS/NZS 4399:1996
- Meets Australian standard AS/NZS 4602.1:2011 for high visibility day wear

SIZE

XS - 5XL

WEIGHT

300gsm

QUALITY

Premium quality 80% polyester / 20% cotton jersey face fleece with hydrophilic moisture management

COLOURS

Yellow/Navy, Orange/Navy

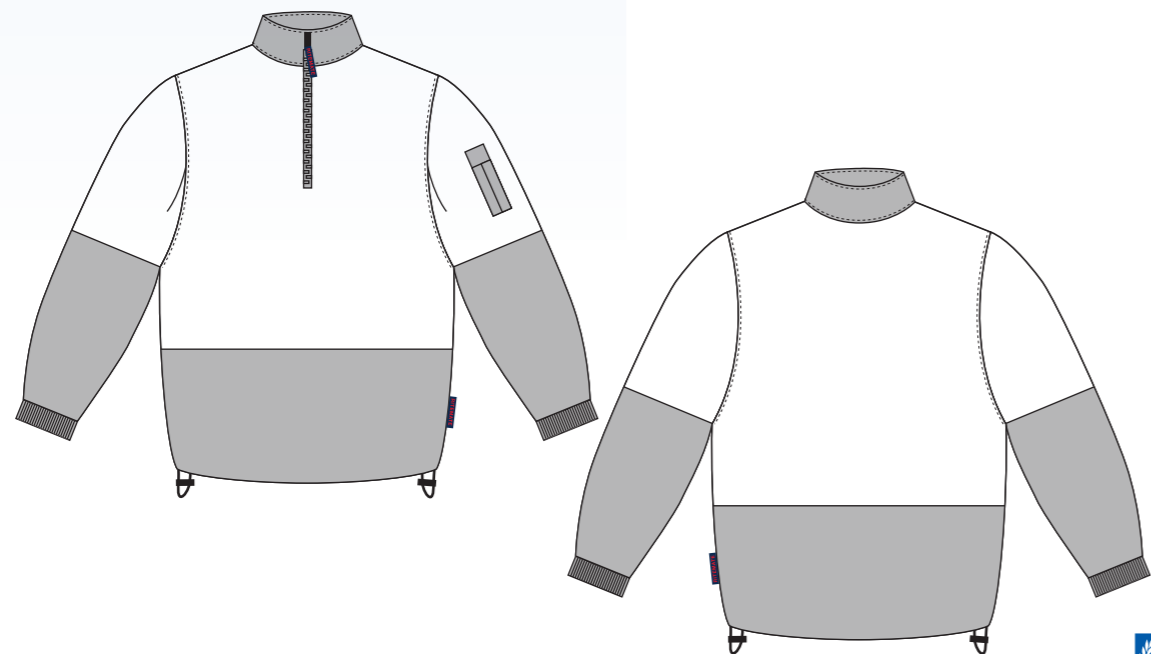

RM6012R

Half zip fleecy pullover with 3M reflective tape

FEATURES

- Pen pocket on upper sleeve
- Zip pull
- UPF 50+ meets Australian standard AS/NZS 4399:1996
- Meets Australian standard AS/NZS 1906.4:2010 & AS/NZS 4602.1:2011 for high visibility day/night wear

SIZE

XS - 5XL

WEIGHT

300gsm

QUALITY

Premium quality 80% polyester / 20% cotton jersey face fleece with hydrophilic moisture management

COLOURS

Yellow/Navy, Orange/Navy

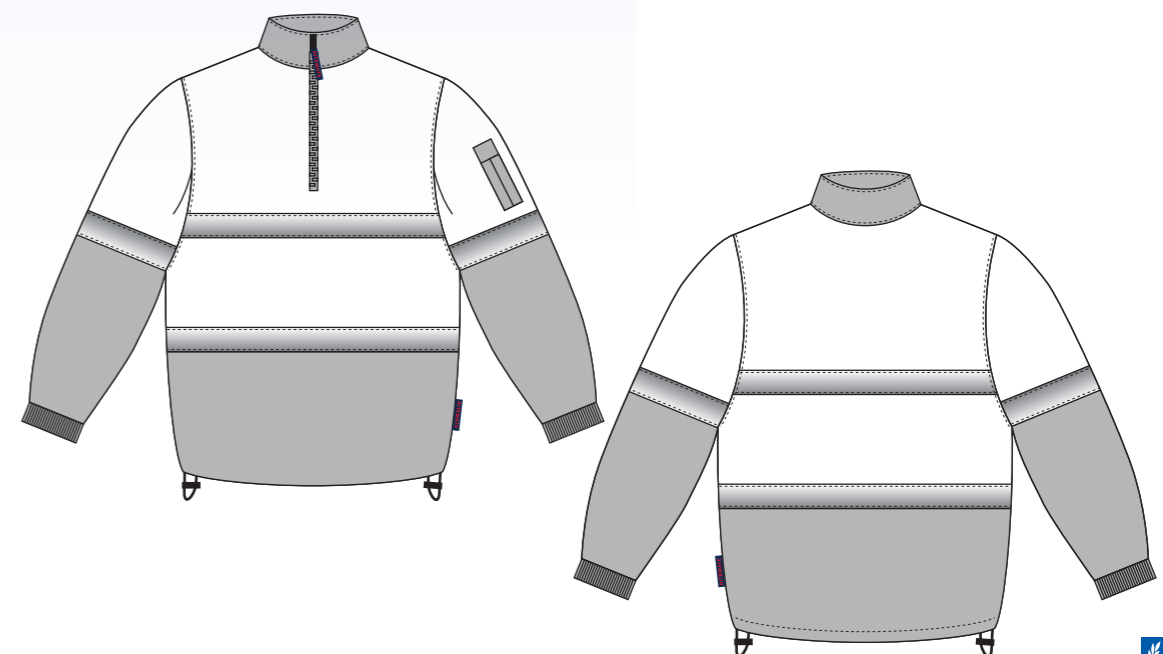

RM5071R

2 tone 100% cotton drill jacket with 3M 8910 reflective tape

FEATURES

- Superior garment assembly, twin needle stitching and bar tacks for extra strength,
- Zip front opening with vislon chunky zipper
- Two front angled side welt pockets, internal zip pocket left side, internal utility pocket right side, internal mobile phone pocket
- Adjustable cuff with touch tape
- Two tone front & back with spliced sleeve
- 50mm 3M 8910 reflective tape hoop configuration front and back
- UPF 50+ meets Australian standard AS/NZS 4399:1996
- Meets Australian standard AS/NZS 1906.4:2010 & AS/NZS 4602.1:2011 for high visibility day/night wear

SIZE

XS - 5XL

WEIGHT

311gsm

QUALITY

Premium quality mercerized, double pre-shrunk, 100% cotton drill

COLOURS

Yellow/Navy, Orange/Navy

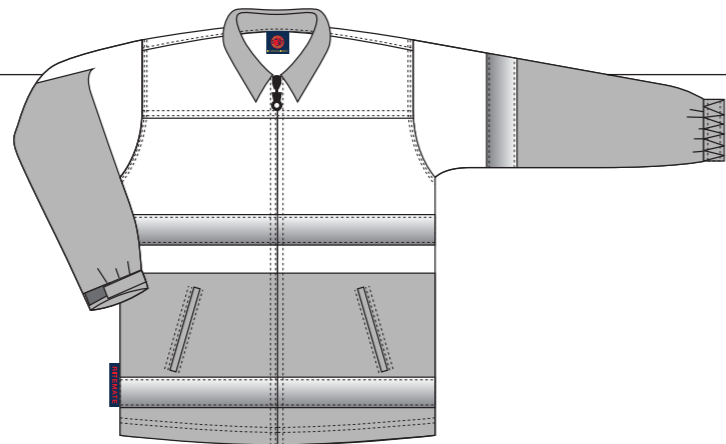
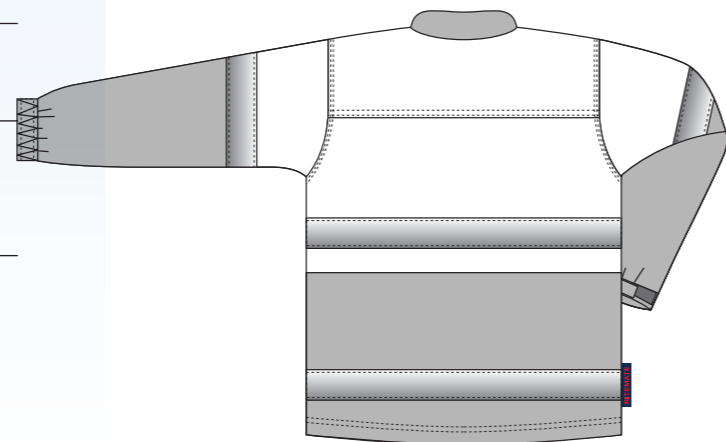

RM73N1R

4 in 1 two tone 100% cotton drill jacket with 3M 8910 reflective tape

FEATURES

- Superior garment assembly, twin needle stitching and bar tacks for extra strength,
- Zip front opening with vislon chunky zipper
- Two front pockets, two side hand warmers, internal pocket on left hand chest with touch tape
- Two tone front & back with spliced sleeve
- 50mm 3M 8910 reflective tape hoop configuration front and back
- UPF 50+ meets Australian standard AS/NZS 4399:1996
- Meets Australian standard AS/NZS 1906.4:2010 & AS/NZS 4602.1:2011 for high visibility day/night wear

SIZE

XS - 5XL

WEIGHT

311gsm

QUALITY

Premium quality mercerized, double pre-shrunk, 100% cotton drill

COLOURS

Yellow/Navy, Orange/Navy

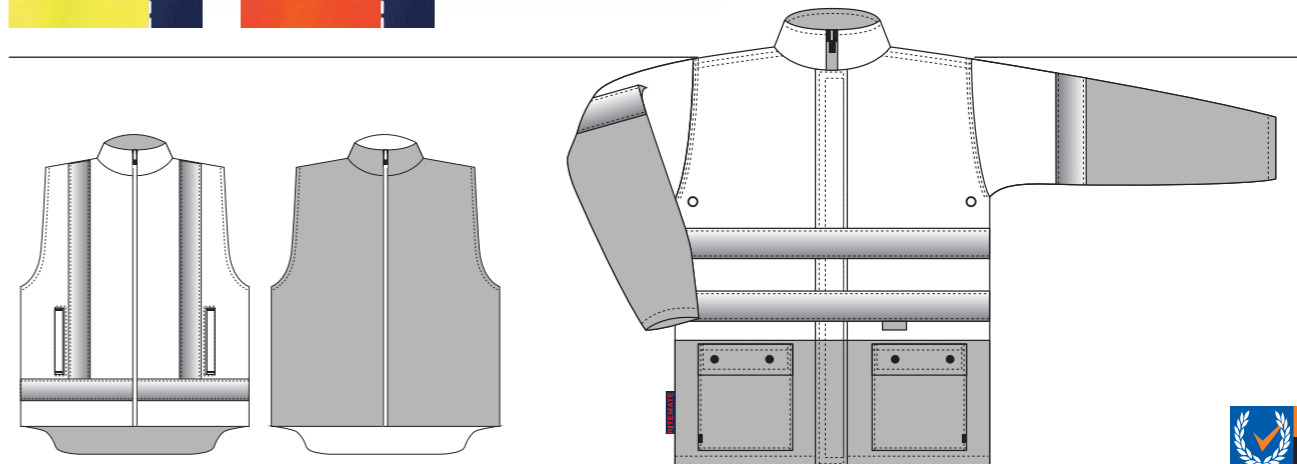
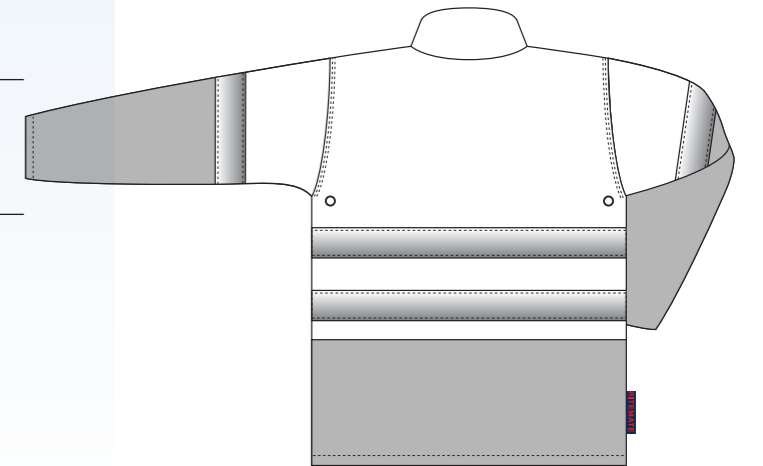

SIZE CHARTS

COVERALLS

METRIC SIZES	REGULAR SIZES										STOUT SIZES									
	72R	77R	82R	87R	92R	97R	102R	107R	112R	117R	87S	92S	97S	102S	107S	112S	117S	122S	127S	
CHEST CM	99	102	109	113	120	125	131	136	140	147	107	114	118	123	128	134	138	143	148	
WAIST CM	91	93	100	104	110	115	119	124	130	136	102	107	113	116	122	127	132	137	142	
EXTENDED																				

MEN'S TROUSERS AND JEANS

METRIC SIZES	REGULAR SIZES										STOUT SIZES										LONG SIZES			
	72R	77R	82R	87R	92R	97R	102R	107R	112R	117R	87S	92S	97S	102S	107S	112S	117S	122S	127S	79L	84L	89L	94L	
WAIST CM	72	77	82	87	92	97	102	107	112	117	87	92	97	102	107	112	117	122	127	79	84	89	94	

LADIES JEANS

METRIC SIZES	REGULAR SIZES									
	6	8	10	12	14	16	18	20	22	24
WAIST CM	68	73	78	83	88	93	98	103	108	113

SHORTS

LADIES SIZES	REGULAR SIZES									
	8	10	12	14	16	18	20	22	24	26
MEN'S SIZES	72R	77R	82R	87R	92R	97R	102R	107R	112R	117R
WAIST CM	72	77	82	87	92	97	102	107	112	117

POLOS, VEST, MENS SHIRTS & JACKETS

LADIES SHIRTS

SIZES	REGULAR SIZES										SIZE CODE	REGULAR SIZES							
	2XS	XS	S	M	L	XL	2XL	3XL	4XL	5XL		6	8	10	12	14	16	18	20
RELAXED CHEST	92	96	100	106	114	122	132	140	148	154	RELAXED CHEST	85	90	96	102	107	114	122	130
NECK CM	32/33	34/35	36/37	38/39	41/42	43/44	45/46	48/49	50/51	52/53	NECK CM	37	38	39	40	41	42	43	44

KIDS SHIRTS

SIZES	0	1-2	3-4	5-6	7-8	9-10	11-12	13-14
RELAXED CHEST	58	63	68	74	80	85	92	98

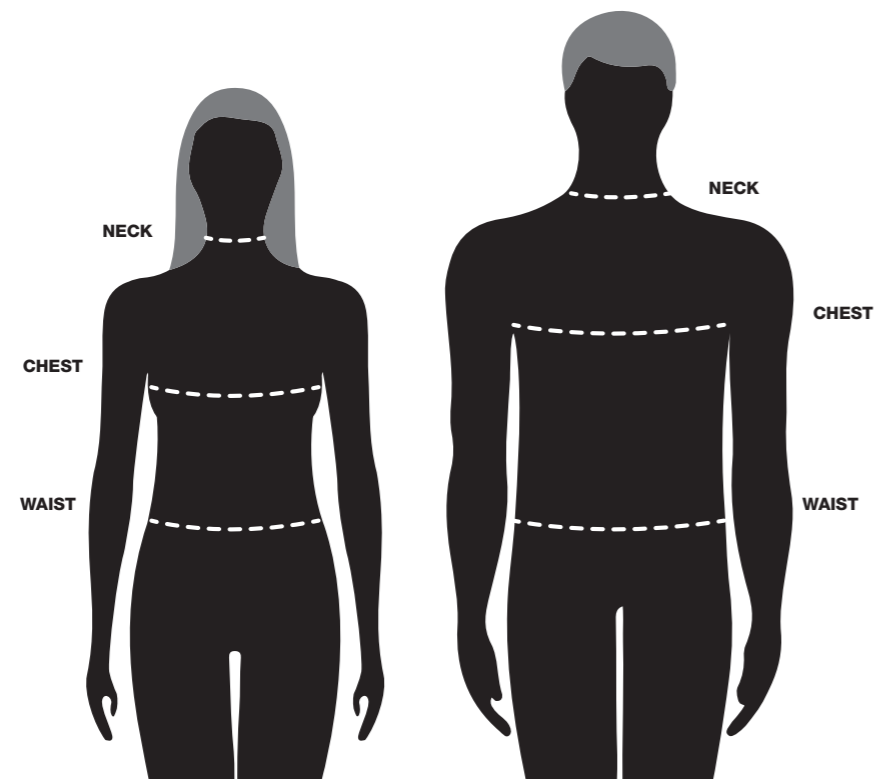

For a comfortable fit it is important to measure correctly.
When measuring make sure the tape is level and not tight.

- NECK** Measure around the neck where the top of the shirt collar would sit – Leaving room for comfort
- CHEST** Standing naturally, measure around the fullest part of the chest and shoulder blades measuring under the arms
- WAIST** Measure over undergarments around your natural waistline

NOTES



www.ritemate.com.au